

# Best of

#2/2024

New products and top promotions

## The new Giraffe: It's that easy to get to the top

### **NEW!** The new GE 6 R

The lightest Giraffe® ever

→ Page 2

### **NEW!** The new 12 V generation

Small, light and handy: And with mega power

→ Page 6

### **NEW!** 18 V cordless sander

Flexible from surface to detail

→ Page 12

### **NEW!** 18 V cordless benchtop circular saw

In heavy use everywhere

→ Page 15

**FLEX**  
this is performance

# The new GE 6 R - the lightest Giraffe® of all time.

## Lightness and stability

The new carbon guide tube gives the power-up to your performance! Carbon is stronger than steel but lighter than aluminium. The carbon tube makes the new GE 6 R the lightest Giraffe® of all time, weighing just 2.8 kg. That makes it perfect for your missions.

## Very quiet operation

Very quiet operation means that there is almost no vibration. With it you can easily take your surfaces to a new level.

## Perfect balance

Level up! Thanks to the new inline design, the GE 6 R performs with perfect balance and optimum ergonomics. It couldn't be better!

## Maximum flexibility

You win! The sanding head's new geometry gives you a very high degree of flexibility. You can even work vertically on the ceiling or very close to the wall.

**NEW**

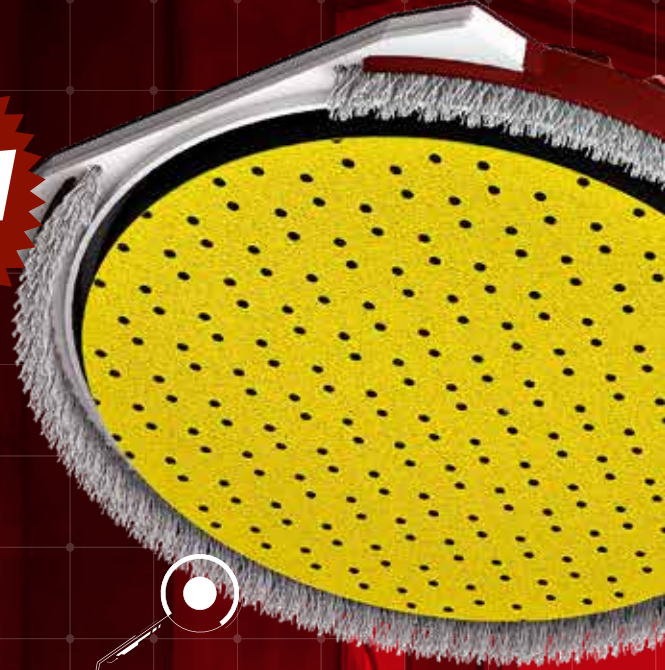

**A very flat sanding head**

### Order No. 530900

- 1x GE 6 R
- 1x round sanding head with pivoting edge segment
- 1x carrying bag

Lightness



Work progress



Ergonomics



Quality







**160° pivoting range**

**Electronic speed control**



**Brushless motor**



**Carbon guide tube  
40% lighter than aluminium  
10x harder than steel**

Watch the video!



## Giraffe® GE 6 R-EC + safety vacuum cleaner VCE 33 M AC

- See P. 2 for the features of the GE 6 R-EC
- See P. 31 for the features of the VCE 33 M AC

### Order No. 533564

- 1x Giraffe® GE 6 R-EC
- 1x segmented sanding head with rotatable edge segment
- 1x clip quick-action clamping ring SH-FC 32
- 1x pack (12 sheets) hook and loop sandpaper, extra-fine 150 grit
- 1x pack (12 sheets) hook and loop sandpaper, extra-fine 220 grit
- 1x carrying bag



- 1x safety vacuum cleaner VCE 33 M AC
- 1x L-BOXX® 102
- 1x cleaning kit
- 1x 4 m antistatic suction hose



## Giraffe® GE 5 ECO



- Easy handling thanks to optimised balance between motor and sanding head
- Reliable power transmission, great flexibility thanks to the flexible drive shaft.

### Order No. 474835

- 1x Giraffe® GE 5 boxed
- 1x clip adapter SAD-C D36/27 AS/NL



## Mobile workstation for wall and ceiling sanding systems GM 270

- Mobile workstation for mounting the Giraffe types GE 5 / 6 / 7 and GDE 10
- Reduced fatigue and strain significantly save the user's strength!
- Tool-free and quick Giraffe® changing thanks to clamping into a sturdy tool holder, and tool-free working height adjustment
- Optimum contact pressure on the grinding surface thanks to gas pressure spring
- The Mobile Giraffe is ready for use quickly, and can be assembled without tools thanks to quick-action elements. The base plate can be fixed on the VCE 33/44 vacuum cleaners with an L-BOXX® attachment. Just secure the lifting rod to the folding system and clamp the Giraffe in place
- Max. working height 2.7 m
- Weight 8.0 kg



Compact and handy, fits in any vehicle.



Tool-free and quick Giraffe® changing thanks to clamping into a sturdy tool holder.

### Order No. 530596

- 1x GM 270
- 1x carrying bag
- 1x L-BOXX® 136 carrying case



You'll find the right industrial vacuum cleaner on Pages 30/31 or at [www.flex-tools.com](http://www.flex-tools.com)





Accessories



Sanding disc, 225 mm diameter

Product	Type/grit	QTY.	Order No.	
 <p>The tried-and-tested premium sandpaper with uncompromising quality and outstanding suction thanks to Multihole. Suitable for almost all applications.</p>	P 40	25	280739	
	P 60	25	260233	
	P 80	25	260234	
	P 100	25	260235	
	P 120	25	282405	
	P 150	25	311995	
	P 180	25	311987	
	P 220	25	260236	
	 <p><b>NEW</b> Sandpaper, wall/ceiling Xtreme quality</p> <p>The sandpaper for extreme removal. Universal and extremely economical.</p>	P 24	12	531542
		P 40	12	531900
P 60		12	531901	
P 80		12	531902	
P 100		12	531896	
P 120		12	531897	
P 150		12	531898	
P 180		12	531543	
P 220		12	531899	
 <p><b>NEW</b> Sandpaper, extra-fine Xtreme quality</p> <p>The super finishing paper for extra-fine surface quality. Particularly suitable for soft materials.</p>		P 40	12	531908
	P 60	12	531909	
	P 80	12	531544	
	P 100	12	531903	
	P 120	12	531904	
	P 150	12	531905	
	P 180	12	531906	
 <p><b>NEW</b> Sandpaper, ZIRCOFLEX Xtreme quality</p> <p>The sandpaper for extremely high removal and ideal for cleaning surfaces.</p>	P 24	12	531918	
	P 40	12	531916	
	P60	12	531917	
 <p>Hook and loop perforated sanding paper</p>	K 80	25	260237	
	K 100	25	260230	
 <p>Hook and loop sanding pad</p>	A 100	10	281042	
	A 180	10	281034	

Interface pad/carrier plate

 <p><b>NEW</b> Universal pad, medium</p>	IP D225-10 M GE 6 R	532674
	Medium interface pad for extra-fine sandpaper	IP D225-10 MF GE 6 R
 <p><b>NEW</b> Support plate D225</p>	BP D225-10 GE 6 R	532221

Carrying bag

Product	Type	Order No.
 <p><b>NEW</b> Carrying bag</p>	TB GE 6	532234

Extension

 <p><b>NEW</b> 50 cm extension</p>	EB 500 GE 6	532222
--	-------------	--------

Adapter GM 270

 <p><b>NEW</b> Insert for tool holder GM 270 for GE 6</p>	GM270-IR GE 6	533083
---	---------------	--------

12 V power

# Small, light, handy. And with mega power.

Just don't underestimate it. The new 12 Volt generation.

**NEW**



**12V**

**Li-Ion**  
Power System

**100% compatible with the existing 10.8 volt FLEX battery system!**



**Cordless drywall screwdriver  
DW 37 12-EC C**

**NEW**



Order No. 531707

**Cordless jigsaw with  
pendulum action  
JSP 12-EC C**

**NEW**



Order No. 531316

**Cordless reciprocating saw  
RS 16 12-EC C**

**NEW**



Order No. 531314

**Cordless combination rotary  
hammer drill  
FHE 1-16 12-EC C**

**NEW**



Order No. 531709

**2-speed cordless hammer  
drill driver PD 2G 12-EC**



Order No. 532273

**2-speed cordless drill driver  
DD 2G 12-EC**



Order No. 532272

**2-speed cordless drill driver  
DD 2G 10.8-LDBC/2.5**

**34 Nm**

- Handy
- Narrow handle
- Very light



Order No. 516155

**360° cordless crossline laser  
ALC 3/360-G/R 10.8**



Order No. 490261

**Cordless polisher, rotary and  
random orbital free-running  
PXE 80 10.8-EC**



Order No. 469068

**12/18 V LED cordless  
full-spectrum lamp  
DWL 2500 12/18**



Order No. 532325

**12/18 V LED cordless build-  
ing site spotlight  
CL 5000 10.8/18.0**



Order No. 504602

**12/18 V LED cordless build-  
ing site spotlight  
CL 10000 10.8/18.0**



Order No. 504610

**12/18 V digital construction site radio RD 12/18/230**

Order No. 532276











**12/18 V digital construction site radio RD SP 12/18/230**

Order No. 532813



**12V**  
**Li-Ion**  
**Power System**

**Accessories**

Product	Type	Description	Order No.
	CA 12	<ul style="list-style-type: none"> <li>for 12 V battery packs</li> <li>Integrated battery pack cooling, overheating, discharge and overload protection</li> <li>With LED charge indicator</li> </ul> <p><b>Charging times, 12 V batteries</b></p> <ul style="list-style-type: none"> <li>40 min for 2.5 Ah battery pack</li> <li>50 min for 5.0 Ah battery pack</li> </ul>	532286
 <p><b>NEW</b></p> <p><b>Available from October 2024</b></p>	P-set 12-22 Q	<ul style="list-style-type: none"> <li>Quick charger CA 12</li> <li>2x battery packs 2.5 Ah 12.0 V</li> </ul>	531719
	AP 12/2.5		532290
	AP 12/5.0		531690
	WV 12-EC		532293
	BV 12-EC		532294
	BF 12-EC		532292
	PS 12/18		532279



# Get the 12 V STACKPACK™ kit!

Available from  
October 2024

Now at  
a value  
price!



## STACKPACK™ value kit consisting of:

- Roller Box TK-L SP RB
- Cordless drywall screwdriver DW 37 12-EC
- Cordless jigsaw JSP 12-EC
- Cordless reciprocating saw RS 16 12-EC
- Cordless combination rotary hammer drill FHE 1-16 12-EC
- 2-speed cordless hammer drill driver PD 2G 12-EC
- 2x P-kit 12-22 Q

You'll find other STACKPACK™ range items on Pages 52/53

# FLEX 18 V battery system with XLITHIUM POWER

The patented Proformance battery system delivers what it promises!



**18V**  
Li-Ion  
Power System

Long run time, long service life, long maximum performance. Only from FLEX: With the patented cooling system, FLEX delivers optimum tool and the battery cell protection. The battery management system controls the permanent data exchange between the tool, battery and charger so that all parameters are optimally set. This ensures power when the battery and tool are working together, and allows you to use them without energy loss.

## Li-ion battery packs

Integrated charge and discharge protection Protected against dust and splash water Integrated charge indicator. Shows at a glance the charge of the battery cells.

**3**  
YEARS  
FLEX WARRANTY

**3-year warranty**  
Also applies to battery packs and chargers.

See Page 54 for details

## AP 18.0 V



Order No.	532732	532733	532748
AP 18.0 V	2.5 Ah	5.0 Ah	8.0 Ah

## P-set 18-88 R

Available from  
October 2024

- 1x rapid charger CA 12/18
- 2x 18 V battery pack AP 18/8.0



Order No. **533175**

## P-kit 55 R

- 1x rapid charger CA 12/18
- 2x 18 V battery pack AP 18/5.0



Order No. **532739**

## P-kit 22 Q

- 1x charger CA 18
- 2x 18 V battery pack AP 18/2.5



Order No. **532740**





### Keep Control

The smart technology controls and monitors the tool activity and the charging process, and provides information on the charging status via the LCD display.



### Therma-Tech™

The unique, integrated cooling system ensures constant temperatures even under heavy loads.



### Power battery

Powerful Li-ion cells provide 18 V power.



### Lithium-ion

No self-discharge. No memory effect.



### EC motor

Low-wear and brushless motor with EC technology for greater running performance, more power and a longer service life.

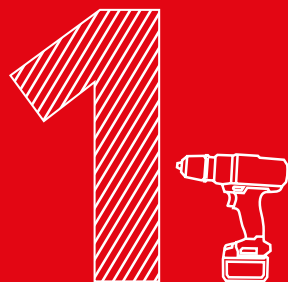

Cordless tool



Therma-Tech™ technology



Charger

# Duo power

## 12/18 V double charger CA SP 2x 12/18



With LED charge indicator



2 x 150 W ensures fast and simultaneous charging of 12 and 18 V batteries.

- The quick charger has space for two batteries and simultaneous charging of 12 V and 18 V battery packs
- With integrated battery pack cooling, overheating, discharge and overload protection.
- Cable winder on the housing keeps things tidy
- The quick-charger is compatible with the FLEX STACKPACK™ transport system and can be mounted on the boxes/organiser.
- With fixture for wall mounting



### 12/18 V double charger CA SP 2x 12/18

- 1x CA SP 2x 12/18

#### Charging times, 18 V batteries

- 40 min for 2.5 Ah battery pack
- 60 min for 5.0 Ah battery pack
- 95 min for 8.0 Ah battery pack

Order No.



533152

Available from October 2024

### Charger CA 12/18

- For 12 V and 18 V battery packs
- Integrated battery pack cooling, overheating, discharge and overload protection
- LCD display

#### Charging times, 18 V batteries

- 40 min for 2.5 Ah battery pack
- 50 min for 5.0 Ah battery pack
- 75 min for 8.0 Ah battery pack

Order No.



The large-format LCD display with a charge time and charge indicator shows the remaining charge time.



532280

# Cordless to the very last detail

## 18 V cordless random orbit sander with speed control ORE 2-125 18-EC



- Lightweight, compact single-hand random orbit sander, very ergonomic and low-vibration
- Brushless motor with greater efficiency and a longer service life
- Electronic Management System (EMS)
- Ergonomically designed, handy grip cap with Soft-Grip inlay
- Sanding speed suitable for the material thanks to electronic speed adjustment in 4 steps
- Electronic switch for simple, safe operation with quick-stop function
- Connector for external dust extraction Ø 27 mm
- Integrated extraction with dust filter bag
- Velcro backing pad with multi-hose system for all standard sanding pads

Order No. 532081

- 1x ORE 2-125 18-EC
- 1x dust bag
- 1x adapter, short
- 1x adapter, long



Also available as a kit in an L-BOXX® (Order No. 532082) and as complete kit including batteries and charger in an L-BOXX® (Order No. 532083).



## 18 V cordless orbital sander with speed control OSE 2-80 18-EC



- same as ORE 2-125 18-EC

Order No. 532084

- 1x OSE 2-80 18-EC
- 1x dust bag
- 1x adapter, short
- 1x adapter, long



Also available as a kit in an L-BOXX® (Order No. 532085) and as complete kit including batteries and charger in an L-BOXX® (Order No. 532086).



## 18 V cordless delta sander with speed control ODE 2-100 18-EC



- same as ORE 2-125 18-EC

Order No. 532087

- 1x ODE 2-100 18-EC
- 1x dust bag
- 1x adapter, short
- 1x adapter, long



Also available as a kit in an L-BOXX® (Order No. 532088) and as complete kit including batteries and charger in an L-BOXX® (Order No. 532089).



You'll find the right industrial vacuum cleaner on Pages 30/31 or at [www.flex-tools.com](http://www.flex-tools.com)





Accessories



Hook and loop sanding disc, 125 mm diameter

Product	Type/grit	QTY.	Order No.
<b>NEW</b>  Hook-and-loop sandpaper ZIRCOFLEX	A 40	12	532039
 Natural fibre felt pad The pad for polishing and waxing surfaces.	A 60	12	532040
	A 80	12	532041
	hard	5	393347
 SC hook-and-loop backed disc The sanding fleece for all paints.	soft	5	393355
	coarse	10	358614
 MESHFLEX hook-and-loop sanding fleece	medium	10	358622
	very fine	10	358630
	A 100	5	380717
 Diamond sanding pad For cleaning, sanding and polishing mineral surfaces.	A 280	5	380725
	S 1500	5	380733
	50	1	382817
<b>NEW</b>  Sandpaper, extra-fine Xtreme quality The all-round sandpaper suitable for almost all applications.	100	1	382825
	200	1	382833
	400	1	382841
	800	1	382868
	1500	1	382876
	3000	1	382884
	P 40	25	531922
P 60	25	531923	
P 80	25	531924	
P 100	25	531925	
P 120	25	531926	
P 150	25	531549	
P 180	25	531550	
P 220	25	531927	
P 320	25	531551	
P400	25	531552	

Hook-and-loop backing pad, 125 mm diameter

Product	Type	QTY.	Order No.
 Hook-and-loop backing pad medium	SP-M D125-M	1	468975



Hook-and-loop sanding pad, 80 x 133 mm diameter

Product	Type/grit	QTY.	Order No.
 MESHFLEX hook-and-loop sanding fleece	A 100	5	380946
	A 280	5	380954
	S 1500	5	380962
<b>NEW</b>  Sandpaper, extra-fine Xtreme quality The all-round sandpaper suitable for almost all applications.	P 40	25	531928
	P 60	25	531929
	P 80	25	531930
	P 100	25	531931
	P 120	25	531832
	P 150	25	531553
	P 180	25	531554
	P 220	25	531933
	P 320	25	531555

Hook-and-loop sanding pad, 100 x 150 mm

Product	Type/grit	QTY.	Order No.
 Hook-and-loop sanding fleece MESHFLEX	A 100	5	381160
	A 280	5	381179
	S 1500	5	381187
<b>NEW</b>  Sandpaper, extra-fine Xtreme quality The all-round sandpaper suitable for almost all applications.	P 40	25	531934
	P 60	25	531935
	P 80	25	531936
	P 100	25	531937
	P 120	25	531938
	P 150	25	531560
	P 180	25	531561
	P 220	25	531939
	P 320	25	531562

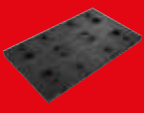
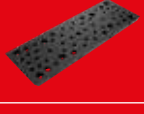
Hook-and-loop backing plate

Product	Type	QTY.	Order No.
 Hook-and-loop backing plate 80 x 130 mm	SP 80x130-M	1	469009
 Hook-and-loop backing plate 70 x 198 mm	SP 70x198-M	1	531313
 Hook-and-loop backing plate 100 x 150 mm	SP 100x150-M	1	468991

# Great performance, safe handling

**18 V cordless angle grinder LBP 125-15 18-EC with dead man's switch and brake 125 mm**



- Powerful angle grinder for industrial applications, particularly cutting and grinding metal.
- Electronic Management System (EMS)
- Brushless motor with greater efficiency and a longer service life
- Microprocessor electronics with soft start, restart protection after power failure, temperature monitoring, overload protection, CDC constant electronics
- With electronic brake, stops the tool in approx. 3 seconds
- Anti-kickback, switches off the motor if the wheel gets jammed
- Perfect dust protection thanks to removable protective metal grille
- Extremely streamlined handle section with soft-grip inlays for perfect handling
- Ergonomic arm working posture thanks to side handle mounted at an angle
- On/Off switch with dead-man function
- Disc guard adjustable without tools
- Spindle lock



**Order No. 531770**

- 1x LBP 125-15 18-EC
- 1x disc guard for grinding
- 1x face spanner
- 1x clamping flange
- 1x clamping nut M 14
- 1x SoftVib handle



# Power pack 68 mm cutting depth

**Cordless circular handsaw with pendulum hood CS 68 18-EC**

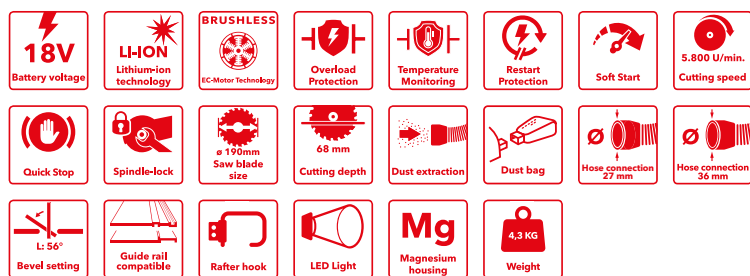

- Maximum cutting depth 68 mm
- Angle scale from 0 ° to 56 °. With preset angles of 22.5° / 45° and 56°. Easy to read and with precision adjustment thanks to long clamping lever
- High-quality disc guard and die-cast magnesium guide plate
- Guide rails for straight, splinter-free and powerful cuts. The guide rail slots are located directly in the base plate. Compatible with FLEX guide rails and guide rails from other manufacturers
- Brushless motor with overload protection and temperature monitoring
- Electronic Management System (EMS)
- Motor brake stops the saw blade in 2 seconds
- Integrated LED lamp for optimum illumination of the work area.
- Spindle lock for rapid saw blade changing
- With metal bracket, non-slip for flexible attachment
- Connector for external dust extraction Ø 27 mm, 36 mm
- Wood shavings collecting bag for low-dust operation, simple to empty



**Order No. 532636**

- 1x CS 68 18-EC
- 1x saw blade D190x1.6/1.0x20 HW Z=24/+17° WZ/DZ
- 1x parallel stop
- 1x dust bag

Also available as a kit in an L-BOXX® (Order No. 532637).



# Compact and efficient up to 92 mm cutting depth

NEW

## 18 V cordless benchtop circular saw TS 92 18-EC

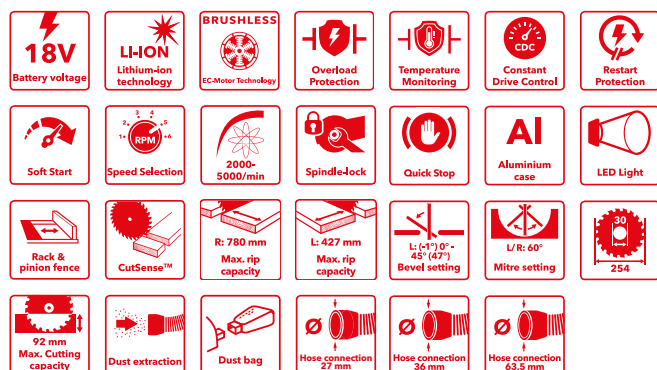

- Brushless 18 V motor with overload protection and temperature monitoring
- The electronic management system (EMS) protects the tool, extends its service life and increases efficiency
- Extremely lightweight cordless table saw for maximum mobility on the construction site. Can be fixed to the folding base frame without tools (optionally available as an accessory)
- Work with the right material at the right speed. The set speed pre-selection is adopted as a constant speed. The result is better cutting quality and a longer saw blade service life
- Comfortable working with CutSense - Auto Mode, the sensor stops the motor after cutting
- High-precision parallel fence with rack and pinion system. Supports longitudinal cuts up to 427 mm on the left side and 780 mm on the right side. Very smooth and quick adjustment
- All attachments such as angle and parallel fence, push stick, protective cover, anti-kickback device, tool spanner and Allen key can be stowed under the table for transport
- Connector for external dust extraction Ø 27 mm, 36 mm
- Wood shavings collecting bag for low-dust operation, simple to empty



Angle stop with long guide profile and fine adjustment, adjustable from 0° to 60° with detent points. For mitre cuts up to 480 mm

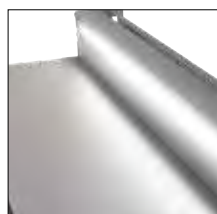

LED lamp integrated in the parallel fence for optimum illumination of the work area. Rechargeable with USB-C.



Cutting capacity of 92 mm with the saw blade measuring just 254 mm. The cutting height can be adjusted easily and precisely using the handwheel



Stepless angle adjustment for mitre cuts from 0-45°



### Order No. 532591

- 1x TS 92 18-EC
- 1x saw blade D254x2.0/1.4x30 HW Z=40/+18° WZ/WZ/DZ
- 1x disc guard
- 1x parallel stop
- 1x angle stop
- 1x splitting wedge
- 1x anti-kickback device
- 1x push stick
- 1x dust bag
- 1x clip adapter SAD-C 36 AS
- 1x suction adapter
- 1x spanner
- 1x Allen key, WAF 5

## Base frame for cordless benchtop circular saw WB Ts

NEW

- Lightweight and stable base frame with comfortable working height of 922 or 942 mm, foldable for transport
- The cordless benchtop circular saw can be attached without tools by using clamps at the front and rear
- With end caps for stability and to protect against scratches

### Order No. 532593

- 1x WB TS



# Hot News

## 18 V cordless hot air gun HG 530 18

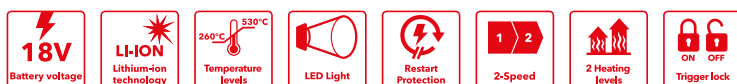

- Compact and ergonomic design
- Powerful hot air blower with 2 temperature settings 260°/530°C and 2 air flow settings
- Quick heating-up to 300°C in ~15 seconds
- Ideally suited to many jobs: Hardening and drying as well as removal of paints and coatings, stickers, moulding and shrinking of plastic parts and shrink tubes, soldering of electrical connections and copper pipe connections
- Can also be used for removing paint and adhesive residues, foiling cars and car parts, spot repair of truck tarpaulins, and for loosening rusted and stuck connections.
- Flat, reflector and reducing nozzle for numerous applications already included in the scope of delivery
- Integrated LED lamp for optimum illumination of the work area.



**NEW**

**Order No. 531493**

- 1x HG 530 18
- 3x nozzles

**FLEX**  
pack

## Hot air gun HG 650 2000

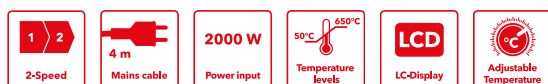

- Powerful heat gun with temperature control in 10° increments from 50°-650°C and 2 air flow settings
- Heats up in seconds
- Very convenient with LCD display for showing the temperature and air flow setting
- Ideally suited to many jobs: Hardening and drying as well as removal of paints and coatings, stickers, moulding and shrinking of plastic parts and shrink tubes, soldering of electrical connections and copper pipe connections
- Can also be used for removing paint and adhesive residues, foiling cars and car parts, spot repair of truck tarpaulins, and for loosening rusted and stuck connections.
- Compact and ergonomic design
- With protective handle for optimum user protection
- Flat, reflector and reducing nozzle for numerous applications already included in the scope of delivery



**NEW**

**Order No. 532579**

- 1x HG 650 2000
- 4x nozzles

## 18 V cordless hot glue gun GG 200 18



- Powerful hot glue gun with 2 temperature settings of 130°/200°C. The reliable gluing performance of 20 g/min enables rapid work progress.
- Quick heating-up within 1 minute thanks to electronically-controlled heating elements
- For many jobs: Fastening and fixing stucco boards, skirting boards, cable ducts, for fabric and leather repairs and for repairing hail damage with an adhesive pad and pull hammer
- Compact and ergonomic design
- Integrated LED lamp for optimum illumination of the work area.



**NEW**

**Order No. 531737**

- 1x GG 200 18

**FLEX**  
pack



# Pure power

## Compact 18 V cordless impact screwdriver IW 1/2" 400 18.0-EC



- Brushless motor
- Electronic Management System (EMS)
- The short head length makes it ideal for screwdriving in confined areas
- Integrated 5-stage LED light
- Square holder for 1/2" impact sockets
- Speed command: Three different speed ranges can be set. One of the benefits is that this prevents small screws from being overtightened
- Auto-Stop mode: When tightening, the machine stops as soon as the blow starts. When loosening, the machine stops as soon as the blow stops. Suitable to prevent over-tightening of the screw or nut.
- Accelerator trigger switch with switch-on lock
- Ergonomically designed, non-slip rubber-coated handle
- Electronic quick-acting brake

Max. loosening torque



NEW

Order No. 531502

- 1x IW 1/2" 400 18.0-EC
- 1x belt clip

FLEX  
pack

Also available as a kit in an L-BOXX®  
Order No. 531503) and as complete kit including batteries and  
charger in an L-BOXX® (Order No. 531504).

## 18 V cordless impact screwdriver IW 1/2" 1500 18-EC

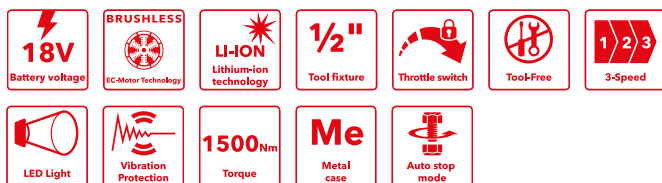

- Brushless motor
- Electronic Management System (EMS)
- Compact design with die-cast aluminium machine head. Extremely durable and impact-resistant
- Speed command: Three different speed ranges can be set. One of the benefits is that this prevents small screws from being overtightened
- Auto-Stop mode: When tightening, the machine stops as soon as the blow starts. When loosening, the machine stops as soon as the blow stops. Suitable to prevent over-tightening of the screw or nut.
- Integrated 5-stage LED light
- Accelerator trigger switch with switch-on lock
- Square holder for 1/2" impact sockets
- Vibration damping: Decoupled, ergonomic handle with rubberised grip surface.
- Electronic quick-acting brake

Max. loosening torque 2000 Nm



NEW

Order No. 532063

- 1x IW 1/2" 1500 18-EC
- 1x belt clip

Also available as a kit in an L-BOXX®  
(Order No. 532064).

## 18 V cordless impact screwdriver IW 3/4" 1600 18-EC

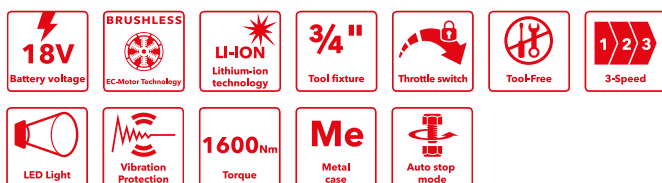

- Technical configuration same as IW 1/2" 1500 18-EC
- Square holder for 3/4" impact sockets



NEW

Order No. 532072

- 1x IW 3/4" 1600 18-EC
- 1x belt clip

Max. loosening torque 2100 Nm

Also available as a kit in an L-BOXX®  
(Order No. 532073).

# 18 V duo power for a clean construction site

**NEW**

2x18 V cordless safety vacuum cleaner with manual filter cleaning, 20 l



- Impressive performance with 2 x 18 V battery packs.
- The high-performance turbine ensures high suction and a high vacuum
- Handy and compact vacuum cleaner, easy to handle and light to carry
- Eco mode, extends the battery runtime to up to 52 minutes with a max. vacuum of 12,000 Pa
- Actuating the manual filter cleaning delivers a targeted blast of air to remove deposited dust from the filter element
- The soft start-up prevents voltage peaks when starting the vacuum cleaner and the deactivation delay (5 seconds' lag) removes dust residue in the suction hose
- With a filter bag made of highly-resistant fleece for optimum filling
- Only for VCE 22 L MC 2x18: Safety vacuum cleaner Class L, suitable for all dusts with TLV values > 1 mg/m<sup>3</sup>.
- Only for VCE 22 M MC 2x18: Safety vacuum cleaner class M, suitable for all dusts with TLV values > 0.1 mg/m<sup>3</sup>. Specially for mineral dusts and wood dusts (including beech and oak)



Self-closing battery compartment, protects the batteries from dirt and moisture



Available from  
October 2024



Only for VCE 22 M MC 2x18: Selector switch suction diameter of 32 mm or 21 mm for optimum flow rate



With large wheels and two swivel guide rollers

## VCE 22 L MC 2x18.0



Dust class

Order No. 531637

- 1x VCE 22 L MC 2x18.0
- 1x suction hose with auxiliary air control Ø 32 mm x 4 m
- 1x adapter



## VCE 22 M MC 2x18.0



Dust class

Order No. 531638

- 1x VCE 22 M MC 2x18.0
- 1x anti-static suction hose Ø 32 mm x 4 m
- 1x adapter





# Let's get loud!

## 12/18 V digital cordless construction site radio RD SP 12/18/230

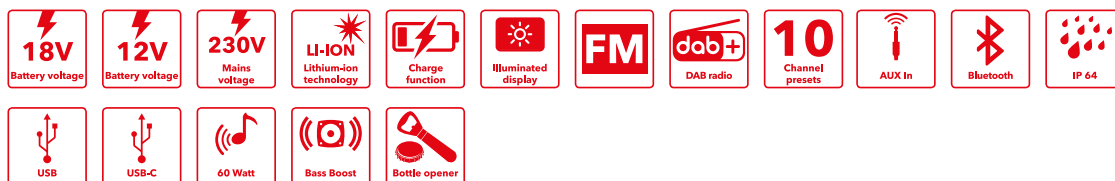

Available from  
October 2024

- Robust construction site radio, for receiving DAB+ and FM
- Loudspeaker output of 2 x 10 W and bass boost for outstanding sound quality
- With integrated Bluetooth® technology, AUX input, USB port and charging option for smartphones, tablets
- Automatic station search and 5 programme presets
- With integrated charger for 12/18 V batteries. The charger starts charging automatically as soon as the mains plug is plugged in



Order No. 532813

- 1x RD SP 12/18/230
- 1x mains cable 230 V



The illuminated display is positioned at an angle. This ensures an unobstructed view of the display and convenient operation



Can be operated with a 12 V or 18 V battery or via the 230 V power supply unit



With integrated bottle opener



The cordless construction site radio is compatible with the FLEX STACKPACK™ storage and transport system

## Cordless edge milling cutter and router CER 18-EC



- An edge milling cutter and router combined. Toolless conversion from the edge milling cutter to the router
- The collet can be used for milling cutters with a shank diameter of up to 8 mm
- With scale zero function, milling depth adjustment via turret stop and infinitely variable milling depth fine adjustment via rotating ring
- The milling table with rubber-coated handles and clamping function enables safe guidance. The Plexiglas base plate always gives the user a clear view of the milling cutter for perfect results
- For a wide range of applications in woodworking, renovation, drywall construction and mould making. Milling of corner joints, joints, curves/contours with templates, re-milling of laminate profiles. Milling solid wood edges, recesses and grooves with templates and guide rings, making templates for production, etc.
- Electronic quick-acting brake
- Connector for external dust extraction Ø 36 mm or step adapter

**FLEX**  
pack



Also available as a 2.5 Ah kit in an L-BOXX® (Order No. 531635) and as 5.0 Ah kit including batteries and charger in an L-BOXX® (Order No. 531636).



### TECHNICAL DATA CER 18-EC

Idling speed	16,000 - 31,000 rpm
Collet diameter	8 mm
Milling stroke (depth)	50 mm
Sound pressure level in acc. with EN 60745	78 dB(A)
Vibration in acc. with EN 60745	1.5 m/s <sup>2</sup>
Battery voltage	18.0 V
Battery capacity	2.5 / 5.0 / 8.0 Ah
Weight without battery pack	1.8 kg

### Order No. 531634

- 1x CER 18-EC
- 1x open-end spanner a/f 17
- 1x base plate D-Format CER
- 1x quick-action stop PG CER
- 1x base plate, round SBB CER
- 1x dust extraction guard SG CER
- 1x collet SPZ CER D6.35
- 1x collet SPZ CER D8



Variable speed adjustment (6 settings).



Quick and easy cutter change thanks to integrated spindle lock.



An edge milling cutter and router combined. Toolless conversion from the edge cutter to the router.



Integrated LED lamp for optimum illumination of the work area.

# FLEX now for the garden too

## 18 V cordless lopper GPS 35 18-EC



- Powerful cordless lopper with 35 mm cutting capacity
- With automatic switch-off after 3 minutes
- **With safety sensor! To protect against finger cuts!**

Order No. 531279

**NEW**

- 1x GPS 35 18-EC
- 1x oil
- Clamping spanner
- 1x Allen key, WAF 2
- 1x Allen key, WAF 4



**FLEX**  
pack

## Cordless leaf blower GBL 790 18-EC



- Compact design, the lightest tool in its class
- 3-level air volume regulation with Boost mode
- Ergonomically-shaped soft handle with on/off switch and lock mechanism for continuous operation

Order No. 531278

- 1x GBL 790 18-EC



**FLEX**  
pack

## Cordless chainsaw GCS 35 2x18-EC



- Powerful 2 x 18 V cordless chainsaw with a saw bar for fast cutting up to approx. 30 cm
- The sturdy metal claw fence fixes the saw
- With recoil brake, stops the chain reliably in 0.12 seconds
- With tool-free chain tensioning via rotary wheel and automatic chain lubrication

Order No. 531276

- 1x GCS 35 2x18-EC



**FLEX**  
pack

Matching accessory:  
Saw chain (Order No. 531302) Saw bar  
(Order No. 531303)

## Cordless hedge trimmer GHT 55 18-EC



- Lightweight and powerful hedge trimmer with rotating handle for optimum handling
- Bar length 55 cm with double-sided dual-action laser-ground blade with a cutting capacity of 25 mm
- Safety double switch to prevent unintentional start-up and an additional hand guard
- Electronic brake stops the tool in 3 seconds

Order No. 531275

- 1x GHT 55 18-EC



**FLEX**  
pack

Matching accessories: Bar, 55 cm (Order No. 531301)

## Cordless lawn trimmer GLT 35 18-EC



- Powerful cordless lawn trimmer with high 2-stage cutting speed, cutting width 30 cm.
- Thread head with "Easy load" - simple adjustment of the thread length by means of automatic inching. With thread cutter and spray guard
- With accelerator trigger switch and continuous operation function

Order No. 531277

- 1x GLT 35 18-EC

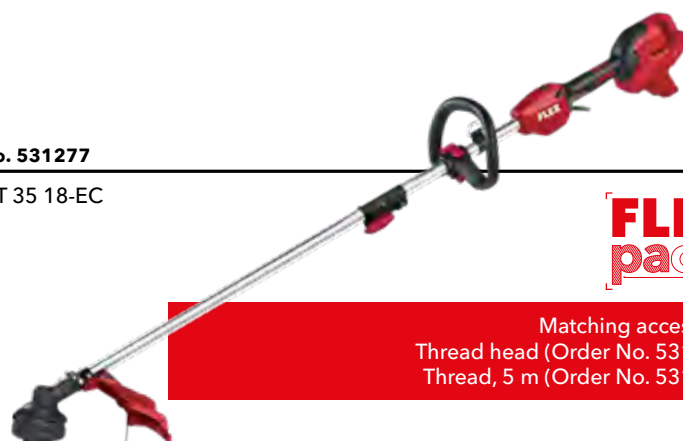

**FLEX**  
pack

Matching accessory:  
Thread head (Order No. 531305)  
Thread, 5 m (Order No. 531304)



# FLEX

# pack

The logo for 'FLEX pack' is presented in a stylized, modern font. 'FLEX' is in a bold, white, sans-serif typeface. 'pack' is in a lowercase, white, sans-serif font with a diagonal hatching pattern. The text is enclosed in a white frame with corner brackets. To the right of 'FLEX' is a circular icon with a 1/4 shaded segment. Below 'pack' is a bar chart with three bars of increasing height. A horizontal line with 'RV' written below it spans across the bottom of the 'pack' text.

# Now even more choice!



Select your 3 new 18 volt tools from the wide FLEX cordless range and make savings not just on the tools: Each FLEX PACK includes three battery packs, a charger and a bag for free. So take what you want. The choice is yours!

**3** tools of your choice

Even cheaper thanks to the FLEX Power promotion!

# The FLEXPACK contains:

## 3 tools of your choice\*

(\*see range on Pages 24/25)

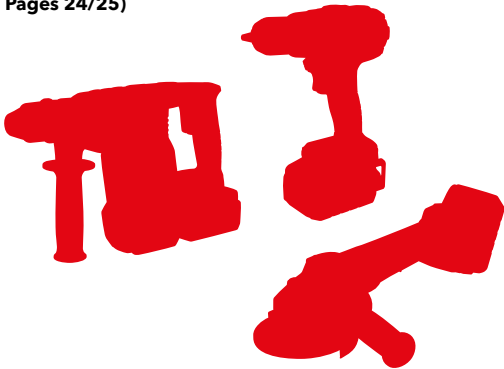

## Rechargeable battery kit

3x Li-ion battery pack AP 18.0/5.0 Ah  
1x rapid charger CA 10.8/18.0



## Bag

1x practical carrying bag made of plastic-reinforced, tear-resistant fabric material



When ordering, please state the following FLEXPACK order number in addition to the listed tool order numbers!

**497444**

**Ideal supplement to the FLEXPACK**

The promotion applies only when purchasing three L-BOXXes!



## Economy box kit

Choose three L-BOXXes from the sizes

- ① TK-L 136 (507822, Promotion No. 42)
- ② TK-L 238 (507830, Promotion No. 43)
- ③ TK-L 374 (507849, Promotion No. 44)

and get a bonus matching anti-slip inlay for each

- 3x L-BOXX®
- 3x anti-slip inlay



Example combination of TK-L 136, TK-L 238 and TK-L 374

# 3 tools of your choice

You can choose more than one of the same tool.



**Order No. 491225**

2-speed cordless drill driver  
DD 2G 18.0-EC C

1



**Order No. 491268**

Cordless impact screwdriver  
IW 1/2" 18.0-EC C

1



**Order No. 531737**

Cordless hot glue gun  
GG 200 18



**Order No. 530497**

Cordless angle grinder  
L 125 18.0-EC LD C

1



**Order No. 531272**

2-speed cordless hammer drill driver with Turbo mode  
DD 2G 18.0-EC HD C

1



**Order No. 492612**

Cordless impact screwdriver  
IW 3/4" 18.0-EC C

1



**Order No. 531493**

cordless hot air gun  
HG 530 18



**Order No. 531770**

Cordless angle grinder  
LBP 125-15 18-EC C

1



**Order No. 530531**

2-speed cordless drill driver  
DD 2G 18.0-EC LD

1



**Order No. 491233**

2-speed cordless hammer drill driver  
PD 2G 18.0-EC C

1



**Order No. 517674**

Cordless compact circular saw  
CS 45 18.0-EC C



**Order No. 518867**

Cordless straight grinder  
DGE 25 18.0-EC

1



**Order No. 491292**

4-speed cordless drill driver  
DD 4G 18.0-EC C

1



**Order No. 530532**

2-speed cordless hammer drill driver  
PD 2G 18.0-EC LD

1



**Order No. 491322**

Cordless compact circular saw  
CS 62 18.0-EC C



**Order No. 532081**

Cordless random orbit sander  
ORE 2-125 18-EC C

2



**Order No. 520756**

Cordless impact driver  
ID 1/4" 18.0-EC-HD C

1



**Order No. 515698**

2- Cordless hammer drill driver with Turbo mode  
PD 2G 18.0-EC-HD C

1



**Order No. 531279**

Cordless lopper  
GPS 35 18-EC



**Order No. 532087**

Cordless delta sander  
ODE 2-100 18-EC C

2



**Order No. 491241**

Cordless impact driver  
ID 1/4" 18.0-EC C

1



**Order No. 491276**

Cordless drywall screwdriver  
DW 45 18.0-EC C

1



**Order No. 504491**

Cordless basic motor  
TRINOXFLEX  
BME 18.0-EC C

2



**Order No. 532084**

Cordless orbital sander  
OSE 2-80 18-EC C

2



**Order No. 531503**

Cordless impact screwdriver  
IW 1/2" 400 18-EC C

1



**Order No. 531311**

Cordless combination rotary hammer drill  
FHE 1-16 18.0-EC C

1



**Order No. 518409**

Cordless Multitool  
18.0 V with StarlockMAX  
holder MT 18.0-EC C

1



**Order No. 481491**

Cordless compact vacuum cleaner  
VC 6 L MC 18.0



**Order No. 530231**

Cordless impact screwdriver  
IW 1/2" 750 18.0-EC C

1



**Order No. 491284**

Cordless combination rotary hammer drill  
CHE 18.0 EC C

2



**Order No. 499307**

Cordless angle grinder  
LB 125 18.0-EC C

1



**Order No. 509981**

Cordless compact vacuum cleaner  
VC 2 L MC HIP 18.0-EC



**Order No. 530189**

Cordless impact screwdriver  
IW 1/2" 950 18.0-EC C

1



**Order No. 491314**

Cordless combination rotary hammer drill  
CHE 2-26 18.0 EC C

2



**Order No. 499285**

Cordless angle grinder  
LBE 125 18.0-EC C

1



**Order No. 503002**

Cordless fan  
CF 18.0/230



# FLEX pack



**Order No. 531275**  
Cordless hedge trimmer  
GHT 55 18-EC

**Order No. 489794**  
Cordless jigsaw  
JSB 18.0-EC C **1**

**Order No. 530610**  
LED cordless lamp  
WL 1000 18.0

**Order No. unisex**

M	417998
L	423165
XL	423173

**Order No. 531277**  
Cordless lawn trimmer  
GLT 35 18-EC

**Order No. 485403**  
Cordless jigsaw  
JS 18.0-EC C **1**

**Order No. 504637**  
LED cordless lamp  
WL 2800 18.0

Battery-operated heated jacket  
TJ 10.8/18.0

**Order No. 531278**  
Cordless leaf blower  
GBL 790 18-EC

**Order No. 531634**  
Cordless edge milling cutter and router  
MT 18.0-EC C **2**

**Order No. 513075**  
LED cordless lamp  
WL 300 18.0

	men	women
XS	-	512052
S	512176	512060
M	512168	512079
L	512141	512192
XL	512184	512095
XXL	512125	512109
3XL	512117	-

**Order No. 472913**  
Cordless fan  
BW 18.0-EC

**Order No. 506648**  
Cordless inflator  
CI 11 18.0/12V

**Order No. 504610**  
LED cordless lamp  
CL 10000 10.8/18.0

Battery-operated heated jacket, fleece  
TF White 10.8/18.0

**Order No. 530372**  
Cordless reciprocating saw  
RS 25 18.0 C **1**

**Order No. 495964**  
2-speed cordless mixer  
MXE 18.0-EC  
WR2 120  
**incl. WR2**

**Order No. 504602**  
LED cordless lamp  
CL 5000 10.8/18.0

	men	women
XS	-	512044
S	511919	512036
M	511927	512028
L	511935	512001
XL	511943	511994
XXL	511951	511986
3XL	511978	-

**Order No. 515981**  
Cordless reciprocating saw  
RS 29 18.0 C **2**

**Order No. 484857**  
Cordless building site radio  
RD 10.8/18.0/230

**Order No. 486728**  
LED cordless full-spectrum lamp  
DWL 2500 10.8/18.0

Battery-operated heated jacket, soft shell  
TJ White 10.8/18.0

**Order No. 491306**  
Cordless reciprocating saw  
RSP DW 18.0-EC C **2**

**Order No. 532748**  
18 V battery pack  
AP 18.0/8.0

**Order No. 472921**  
LED cordless building site spotlight  
CL 2000 18.0

**Order No. 531748**  
Cordless band saw  
SBE 64 18-EC **2**

**NEW**  
**Order No. 533152**  
Cordless double charger  
CA SP 2x 12/18

**Order No. 530375**  
LED cordless building site spotlight  
TL 4000 18.0/230

**Order No. 531276**  
Cordless chain saw  
GCS 35 2x18-EC

**Order No. 531330**  
Cordless vacuum lifter  
VLP 18.0 C **2**

**Multiple selection not possible!**

# 18 V promo packs

## 18 V cordless angle grinder L 125 18.0-EC LD/5.0 kit



- Brushless motor
- Extremely streamlined handle section with soft-grip inlays
- With soft start, restart protection after power failure, overload protection
- Anti-kickback, switches off the motor if the wheel gets jammed
- Perfect dust protection thanks to removable protective metal grille
- Ergonomic arm working posture thanks to side handle mounted at an angle
- Disc guard adjustable without tools

Order No. 530496

- 1x L 125 18.0-EC LD
- 1x clamping flange
- 1x clamping nut
- 1x face spanner
- 1x side handle M10
- 1x charger CA 18.0
- 2x battery packs Li-ion AP 18.0/5.0 Ah
- 1x disc guard for grinding, Ø 125 mm
- 1x carrying case



Also available as a boxed solo machine (Order No. 530497)



## 18 V cordless combination rotary hammer drill FHE 1-16 18.0-EC TC 2.5/kit



- Weighing just 1.37 kg, it's the lightest and most powerful 18 V cordless rotary hammer drill in its class
- Brushless motor
- Function switch with two functions: drilling, hammer drilling,
- With accelerator trigger switch and continuous operation function
- Electronic quick-acting brake
- Vibration damping

Order No. 531312

- 1x FHE 1-16 18.0-EC
- 1x charger CA 18.0
- 2x battery packs Li-ion AP 18.0/2.5 Ah
- 1x carrying case



Also available as a boxed solo machine (Order No. 531311)



## 18 V cordless drill driver DD 2G 18.0-EC LD/2.5 kit



- Compact and efficient cordless screwdriver with extremely short head
- Brushless motor
- Accelerator trigger switch with switch-on lock
- Metal quick-clamp chuck with thrust ring and auto-lock function
- Electronic quick-acting brake
- Clockwise/anti-clockwise rotation with safety catch
- Integrated LED light with afterglow function

Order No. 519049

- 1x DD 2G 18.0-EC LD
- 1x charger CA 18.0
- 2x battery packs Li-ion AP 18.0/2.5 Ah
- 1x belt clip
- 1x bit storage
- 1x carrying case



Also available as a cordless hammer drill driver PD 2G 18.0-EC LD/2.5 kit

## 2-speed cordless hammer drill driver PD 2G 18.0-EC FS55BC/5.0



- Bit holder and 13 mm keyless chuck
- Brushless motor

Order No. 516171

- 1x PD 2G 18.0-EC FS55
- 1x charger CA 18.0
- 2x battery packs Li-ion AP 18.0/5.0 Ah
- 1x handle
- Belt clip, bit storage
- 1x carrying case



## Cordless multitool with StarlockMAX holder MT 18.0-EC + cordless drill driver DD 2G 18.0-EC LD



STARLOCK PLUS

STARLOCK MAX

- Oscillation angle of 2° on both sides
- With StarlockMAX tool holder
- Brushless motor
- Anti-vibration damping elements
- Tool-free tool change
- Integrated double LED lamp

Order No. 532843

- 1x MT 18.0-EC
- 1x DD 2G 18.0-EC LD
- 1x charger CA 18.0
- 2x battery packs AP 2.5/18.0 Ah
- 1x carrying case



## Cordless multitool with StarlockMAX holder MT 18.0-EC + cordless drywall screwdriver DW 45 18.0-EC



STARLOCK PLUS

STARLOCK MAX

Order No. 532427

- 1x MT 18.0-EC
- 1x DW 45 18.0-EC
- 1x charger CA 18.0
- 2x battery packs AP 2.5/18.0 Ah
- 1x carrying case



## Screw magazine attachment M-DW 55

Order No. 531747

- 1x screw magazine attachment M-DW 55

### INCLUDING

3x bits, version PH  
size 2, E6,3





# Let there be light

## LED cordless building site spotlight with tripod TL 4000 18.0/230

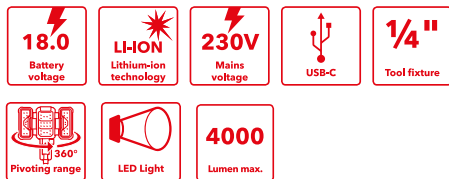

- Powerful cordless building site spotlight with 3 brightness levels of 1000, 2000 and 4000 lumens
- The multifunctional head can be operated as a pure work light directly with an 18 V battery. Can be used fixed with a hook or mounted on a tripod
- Variable-height working range of 1.1-2.2 m with tripod
- The tripod has a 1/4" connection
- Lamp can be turned through 180°
- Multifunction control panel with LED charge level indicator, activation button, On/Off switch and USB-C charging port
- Fast set-up and stability thanks to one-button operation and tripod stand
- The building site spotlight can also be supplied with power directly via a commercially available cold appliance connection cable (**not included!**)
- Suitable for operation with 230 V or 110/120 V

Order No. 530375

- 1x TL 4000 18.0/230



## LED cordless building site spotlights CL 5000 10.8/18.0 and CL 10000 10.8/18.0

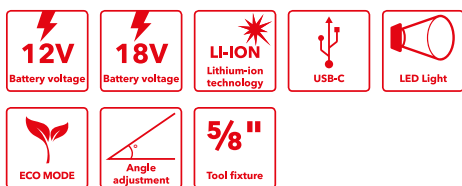

- Powerful 5000 lumens (CL 5000 10.8/18.0) or 10000 lumens (CL 10000 10.8/18.0) cordless building site spotlights with 5 brightness levels plus ECO mode.
- With memory function
- The colour temperature of 5000 kelvin corresponds to a neutral light colour
- Lamp can be turned through 120°
- Visual early-warning system: low battery charge is indicated by slightly decreasing level of brightness.
- 5/8" thread connection for tripods
- With wall mounting option
- Robust and durable for the most exacting demands
- Integrated spacer dome with cooling openings protect the lens and surfaces



Order No. 504602

- 1x CL 5000 10.8/18.0



Order No. 504610

- 1x CL 10000 10.8/18.0



You will find the matching tripod at [www.flex-tools.com](http://www.flex-tools.com)

## 18 V LED cordless lamp WL 300 18.0



- 2 brightness settings, 300 lumen and 150 lumen
- The LED lamp head can be swivelled through 104°.
- Ergonomic grip surfaces with SoftGrip
- With metal bracket for flexible positioning
- or for carrying the lamp and belt clip

Order No. 513075

- 1x WL 300 18.0
- 1x belt clip



**FLEX**  
pack

## 18 V cordless work lamp WL 1000 18.0



- The LED lamp head can be swivelled through 180°+ 270°.
- LED light with 8 LED and 3 brightness levels
- Firm hold thanks to powerful integrated magnets.
- With metal handle for carrying the lamp
- Ergonomic grip surfaces with SoftGrip
- Luminous flux 200 / 500 / 1000 lm
- Colour temperature 4000 CCT

Order No. 530610

- 1x WL 1000 18.0
- 1x belt clip



**FLEX**  
pack

## 18 V LED building site spotlight CL 2000 18.0



- Powerful cordless building site spotlight with two brightness settings, 1,200 and 2,000 lumen
- Lamp can be turned through 360°
- 5/8" thread connection for tripods
- With wall mounting option
- Robust and durable for the most exacting demands
- Visual early-warning system: low battery charge is indicated by slightly decreasing level of brightness.

Order No. 472921

- 1x CL 2000 18.0



**FLEX**  
pack

## 18 V cordless floodlight hand lamp WL 2800 18.0



- LED floodlight with 2 brightness levels
- 2800 lumens with a range of 630 m and 1000 lumens and an additional red LED
- The LED lamp head can be swivelled through 180°
- Can be operated via 12 V on-board voltage (via cigarette adapter, car socket)
- 1/4" thread connection for tripods
- Swivelling and lowerable hook for attaching the lamp and belt clip
- Ergonomic grip surfaces with SoftGrip

Order No. 504637

- 1x WL 2800 18.0
- 1x belt clip
- 1x 12 V connection, car adapter



**FLEX**  
pack

# L Class vacuum cleaner

## Safety vacuum cleaner with manual filter cleaning VC 6 L MC



Order No. 532024

- 1x VC 6 L MC
- 1x suction hose 32 mm Ø x 0.5-2.5 m
- 1x flat-fold filter, Class L
- 1x fleece filter bag, Class L
- 1x hand pipe
- 1x crevice nozzle
- 1x round brush
- 1x upholstery nozzle
- 1x padded carrying strap
- 1x running gear



## Safety vacuum cleaner with manual filter cleaning VC 21 L MC



Order No. 409979

- 1x VC 21 L MC incl. accessories
- 1x extensive cleaning kit
- 5x fleece filter bags FS-F VC/E 21-26 L VE5

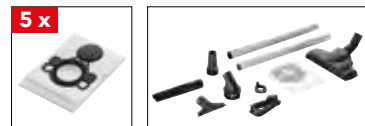

## Safety vacuum cleaner with automatic filter cleaning, S 44 L



Order No. 444146

- 1x S 44 L
- 1x suction hose with auxiliary air control
- 1X PES flat-fold filter
- 1x disposal bag
- 2x extension pipes
- 1X elbow
- 1x clip floor nozzle
- 1x crevice nozzle
- 1x upholstery nozzle
- 1x round brush
- 1x adapter
- 1X expander
- 2x hose holders



## Safety vacuum cleaner with automatic filter cleaning VCE 33 L AC and VCE 44 L AC



- High-performance turbine for high suction power and high negative pressure
- Permanent socket with electronic automatic On/Off
- Flow rate control via rotary switch
- Electronic fill level monitoring during wet suction
- Start-up and switch-off delay
- 15 seconds coasting empties remaining dust in the suction hose
- Dust-protected anti-static features
- Easy filter changing
- Adapter plate for fixing L-BOXXes and Tanos Systemers



VCE 33 L AC, Order No. 471186

- 1x VCE 33 L AC
- 1x anti-static suction hose Ø 32 mm x 4 m
- 1x L-BOXX® holder
- 1x flat-fold filter PES L/M/H
- 1x fleece filter bag Class L/M
- 1x PP disposal bag
- 1x adapter Ø 25-32 mm, anti-static
- 2x hose holders
- 5x fleece filter bags FS-F VCE L/M
- 1x carrying case L-BOXX® TK-L 102
- 1x extensive cleaning kit



VCE 44 L AC, Order No. 471208

- 1x VCE 44 L AC
- Equipment as above



You can find more industrial vacuum cleaners at [www.flex-tools.com](http://www.flex-tools.com)



# M class vacuum cleaner

## 20 l safety vacuum cleaner with manual filter cleaning, Class M VCE 22 M MC and VCE 22 M MC V

- The high-performance turbine ensures high suction power
- With equipment socket and automatic electronic on/off switch
- With soft start and switch-off delay (5 seconds coasting)
- Selector switch suction diameter of 32 mm or 21 mm
- With flow rate control via the rotary switch
- Dust-protected anti-static features
- Safety vacuum cleaner class M, suitable for all dusts with TLV values > 0.1 mg/m<sup>3</sup>. Specially for mineral dusts and wood dusts (including beech and oak)
- Flow sensor technology monitors the flow rate

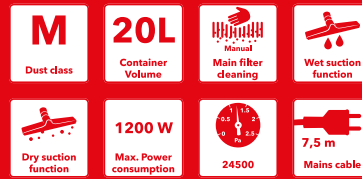

## For construction site use



### Order No. 519812

- 1x VCE 22 M MC
- 1x anti-static suction hose with auxiliary air control
- 1 cleaning kit



## For the automotive sector



### Order No. 530920

- 1x VCE 22 M MC V
- 1x anti-static suction hose



## Safety vacuum cleaner with automatic filter cleaning VCE 33 M AC and VCE 44 M AC



- High-performance turbine for high suction power and high negative pressure
- Permanent socket with electronic automatic On/Off
- Flow rate control via rotary switch
- Electronic fill level monitoring during wet suction
- Start-up and switch-off delay
- 15 seconds coasting empties remaining dust in the suction hose
- Dust-protected anti-static features
- Easy filter changing
- Adapter plate for fixing L-BOXXes and Tanos Systainers



### VCE 33 M AC, Order No. 471194

- 1x VCE 33 M AC
- 1x anti-static suction hose Ø 32 mm x 4 m
- 1x L-BOXX® holder
- 1x flat-fold filter PES L/M/H
- 1x fleece filter bag Class L/M
- 1x PP disposal bag
- 1x adapter Ø 25-32 mm, anti-static
- 2x hose holders
- 5x fleece filter bags FS-F VCE L/M
- 1x carrying case L-BOXX® TK-L 102
- 1x extensive cleaning kit



### VCE 44 M AC, Order No. 471216

- 1x VCE 44 M AC
- Equipment as above

# Proformance with price advantage

The sanding all-rounder for refurbishment work. A unique compact design, effective dust extraction and handy - FLEX palm sanders with speed control are now available at an attractive introductory price.

## Random orbit sander ORE 3-150-EC and ORE 5-150 EC



- Brushless motor
- Adjustable speed
- Effective dust extraction
- With disc brake
- Impact-resistant filter cartridge with replaceable PES filter
- Dust extraction connection Ø 27 mm
- Hook and loop sanding disc with multi-hole system for optimum suction, suitable for all commercially available pads Ø 150 mm



**Order No. 532020**

- 1x ORE 3-150 EC
- 1x medium hook & loop backing pad
- 1x PES microfilter cartridge with filter
- 1x Allen key, WAF 5



**Order No. 532021**

- 1x ORE 5-150 EC
- 1x medium hook & loop backing pad
- 1x PES microfilter cartridge with filter
- 1x Allen key, WAF 5

## Delta sander ODE 2-100 EC Random orbit sander ORE 2-125 EC Orbital sander OSE 2-80 EC



- Low-vibration
- Brushless motor
- Electronic speed control with 4 settings
- Ergonomically designed, handy grip cap with Soft-Grip inlay
- Effective dust extraction thanks to integrated self-extraction with filter cartridge



**Order No. 532017**

- 1x ODE 2-100 EC
- 1x hook & loop backing pad
- 1x PES microfilter cartridge with filter



**Order No. 532018**

- 1x ORE 2-125 EC
- 1x hook & loop backing pad
- 1x PES microfilter cartridge with filter



**Order No. 532019**

- 1x OSE 2-80 EC
- 1x hook & loop backing pad
- 1x PES microfilter cartridge with filter

## Compact orbital sander with speed control OSE 2-70x198-EC



- Ideal for sanding filled surfaces on car parts during repair work. For surface sanding the substrate and avoiding unevenness before applying the filler and using a random orbit sander

**With 70x198 mm backing plate!**



**Order No. 530632**

- 1x OSE 2-70x198-EC
- 1x hook-and-loop backing plate SP 70x198-M

You'll find the right industrial vacuum cleaner on Pages 30/31 · Go to Page 13 for the right pads.

# Causing a real stir

**FLEX professional mixers are causing a stir on the market. Get an ergonomically-optimised solution now for clean, powerful and fast mixing on the construction site. The ideal introductory offer for painters, plasterers or bricklayers.**

**2 helical paddles included with every unit**

**1x WR2 ...x600 M14  
1x WR3R ...x600 M14**



## 1010 watt 2-speed mixer MXE 1000

- For mixing applications up to 40 kg
- Full-wave electronic control: with soft start, temperature monitoring, overload protection, and with continuous speed control via the accelerator trigger switch
- No-load speed 0 - 780/min

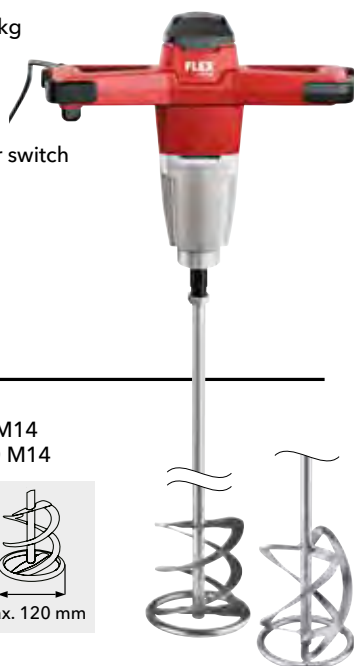

**Order No. 531035**

- 1x 1-speed mixer MXE 1000
- 1x helical paddle WR2 120x600 M14
- 1x helical paddle WR3R 120x600 M14



## 1200 watt 2-speed mixer MXE 1202

- For mixing applications up to 60 kg
- Full-wave electronic control: with soft start, temperature monitoring, overload protection, and with continuous speed control via the accelerator trigger switch
- 3-setting switch / Setting 1: Cleaning, Setting 2: Slow stirring, Setting 3: Mixing
- No-load speed, 1st gear 0 - 210 / 325 / 530/min
- No-load speed, 2nd gear 0 - 320 / 490 / 530/min

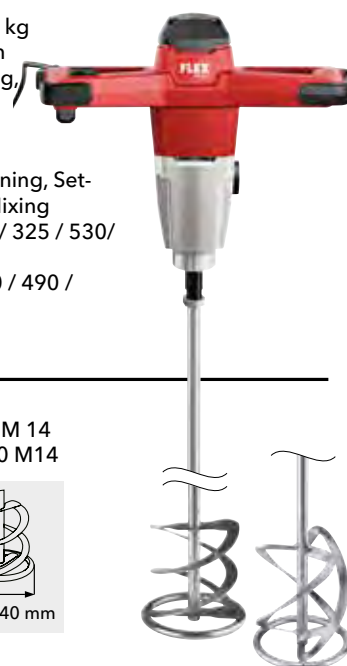

**Order No. 531036**

- 1x 2-speed mixer MXE 1202
- 1x helical paddle WR2 140x600 M 14
- 1x helical paddle WR3R 140x600 M14



## 1600 watt 2-speed mixer MXE 1602

- For mixing applications up to 90 kg
- Sturdy 2-speed gearbox: large size and optimum gear ratio - for speeds to suit the material and a high torque
- with soft start, temperature monitoring, overload protection and stepless speed control via the accelerator trigger switch
- Comfortable 3-setting switch accessible from the handle position without interrupting work, protected by a rubber grommet

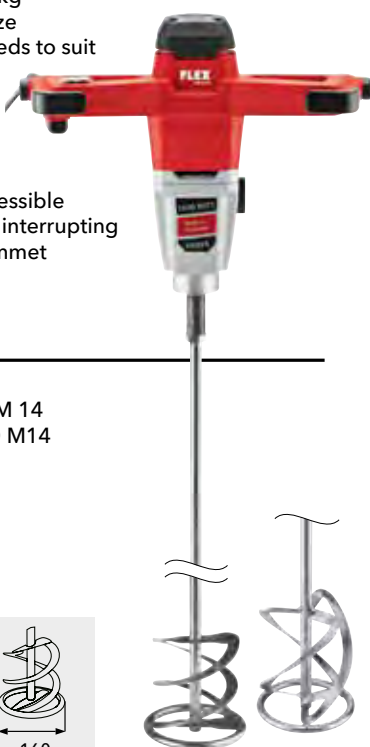

**Order No. 531037**

- 1x 2-speed mixer MXE 1602
- 1x helical paddle WR2 160x600 M 14
- 1x helical paddle WR3R 160x600 M14



## 18 V cordless 2-speed mixer with MXE 18.0-EC 3-setting speed switch



- For mixing applications up to 30 kg
- Electronic Management System
- Accelerator trigger switch
- Robust 2-speed gearbox
- 3-setting switch / Setting 1: Cleaning, Setting 2: Slow stirring, Setting 3: Mixing
- No-load speed, 1st Speed 0 - 210 / 325 / 530 rpm
- No-load speed, 2nd Speed 0 - 210 / 325 / 530 rpm



**Order No. 532031**

- 1x cordless 2-speed cordless mixer MXE 18.0-EC
- 1x charger CA 10.8/18.0
- 2x battery packs Li-ion AP 18.0/5.0 Ah
- 1x helical paddle WR2 120x600 M14
- 1x helical paddle WR3R 120x600 M14





## 4x combination rotary hammer drill CHE 4-32 R SDS-plus



- 900 watt hammer and chisel drill in D-configuration with high-impact energy and low vibrations
- Drilling chuck can be removed without tools
- Rotation stop for chiselling
- Max. drilling range up to 32 mm
- Tool quick-change system SDS-plus
- Function switch with four functions: drill, hammer drill, chisel, chisel adjustment
- Accelerator trigger switch for a slow and sensitive start
- Non-rotating additional handle with depth stop



### Order No. 472018

- 1x CHE 4-32 R SDS-plus
- 1x handle
- 1 x keyless chuck with rotation stop, Ø 1.5-13 mm
- 1x chuck BF SDS-plus
- 1x drilling depth stop
- 1 L-Boxx TK-L 238



**INCLUDING**  
7-piece chiselling/  
drilling kit SDS-plus

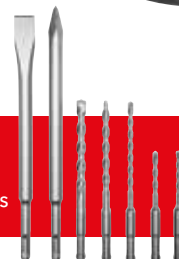

## Chiselling hammer DH 5 SDS-max



- Vibration-dampened rear handle
- Side handle with radial and axial rotation
- Powerful 1,050 watts
- Blows per minute 3,500 rpm
- 12 chisel settings
- Max. individual impact energy (in acc. with EPTA) 6.7 J
- Weight 5.4 kg



### Order No. 532027

- 1x DH 5 SDS-max
- 1x handle
- 1x tube of grease
- 1x carrying case



**INCLUDING**  
2-piece chiselling kit  
SDS-max



## Universal rotary hammer drill CHE 2-28 SDS-plus



- Light 800 watt pistol-shaped rotary hammer and drill chisel hammer
- Max. individual impact energy (in acc. with EPTA) 2.7 J
- Clockwise/anti-clockwise rotation with switchover via carbon brush reverser. As a result, almost identical torque in both directions of rotation
- Drilling with hammer function
- Drilling depth stop: for precise working
- Rotation stop for chiselling
- Max. drilling range up to 28 mm in concrete
- With accelerator trigger switch and continuous operation function
- Ideal for drilling/hammer drilling, 4-18 mm diameter in masonry and concrete for composite, anchor attachment and clearance holes and for light chiselling work to remove plaster and tiles



### Order No. 452327

- 1x CHE 2-28 SDS-plus
- 1x handle
- 1x drilling depth stop
- 1 L-Boxx TK-L 136





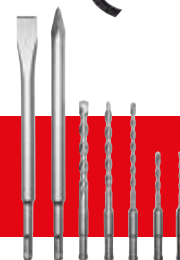





**INCLUDING**  
7-piece chiselling/  
drilling kit  
SDS-plus



# Highest quality thanks to bit with 4 cutting edges



Type	Description	Ø mm	Total length mm	Working length mm	Order No.	
	HD 4-C D5x 50/110 SDS-plus	Hammer drill, 4 cutting edges SDS-plus Xtreme Plus	5.0	110	50	533566
	HD 4-C D6x 50/110 SDS-plus	Hammer drill, 4 cutting edges SDS-plus Xtreme Plus	6.0	110	50	533567
	HD 4-C D8x 50/110 SDS-plus	Hammer drill, 4 cutting edges SDS-plus Xtreme Plus	8.0	110	50	533568
	HD 4-C D5x 100/160 SDS-plus	Hammer drill, 4 cutting edges SDS-plus Xtreme Plus	5.0	160	100	533569
	HD 4-C D6x 100/160 SDS-plus	Hammer drill, 4 cutting edges SDS-plus Xtreme Plus	6.0	160	100	533570
	HD 4-C D6.5x 100/160 SDS-plus	Hammer drill, 4 cutting edges SDS-plus Xtreme Plus	6.5	160	100	533571
	HD 4-C D8x 100/160 SDS-plus	Hammer drill, 4 cutting edges SDS-plus Xtreme Plus	8.0	160	100	533572
	HD 4-C D10x 100/160 SDS-plus	Hammer drill, 4 cutting edges SDS-plus Xtreme Plus	10.0	160	100	533573
	HD 4-C D12x 100/160 SDS-plus	Hammer drill, 4 cutting edges SDS-plus Xtreme Plus	12.0	160	110	533574
	HD 4-C D6x 150/210 SDS-plus	Hammer drill, 4 cutting edges SDS-plus Xtreme Plus	6.0	210	150	533575
	HD 4-C D8x 150/210 SDS-plus	Hammer drill, 4 cutting edges SDS-plus Xtreme Plus	8.0	210	150	533576
	HD 4-C D10x 150/210 SDS-plus	Hammer drill, 4 cutting edges SDS-plus Xtreme Plus	10.0	210	150	533577
	HD 4-C D12x 160/210 SDS-plus	Hammer drill, 4 cutting edges SDS-plus Xtreme Plus	12.0	210	160	533578
	HD 4-C D14x 160/210 SDS-plus	Hammer drill, 4 cutting edges SDS-plus Xtreme Plus	14.0	210	160	533579
	HD 4-C D16x 160/210 SDS-plus	Hammer drill, 4 cutting edges SDS-plus Xtreme Plus	16	210	160	533580
	HD 4-C D6x 200/260 SDS-plus	Hammer drill, 4 cutting edges SDS-plus Xtreme Plus	6.0	260	200	533581
	HD 4-C D6.5x 200/260 SDS-plus	Hammer drill, 4 cutting edges SDS-plus Xtreme Plus	6.5	260	200	533582
	HD 4-C D8x 200/260 SDS-plus	Hammer drill, 4 cutting edges SDS-plus Xtreme Plus	8.0	260	200	533583
	HD 4-C D10x 200/260 SDS-plus	Hammer drill, 4 cutting edges SDS-plus Xtreme Plus	10.0	260	200	533584
	HD 4-C D12x 210/260 SDS-plus	Hammer drill, 4 cutting edges SDS-plus Xtreme Plus	12.0	260	210	533585
HD 4-C D14x 210/260 SDS-plus	Hammer drill, 4 cutting edges SDS-plus Xtreme Plus	14.0	260	210	533586	
HD 4-C D16x 210/260 SDS-plus	Hammer drill, 4 cutting edges SDS-plus Xtreme Plus	16.0	260	210	533587	
HD 4-C D18x 200/250 SDS-plus	Hammer drill, 4 cutting edges SDS-plus Xtreme Plus	18.0	250	200	533588	
HD 4-C D20x 200/250 SDS-plus	Hammer drill, 4 cutting edges SDS-plus Xtreme Plus	20.0	250	200	533589	
HD 4-C D8x 250/310 SDS-plus	Hammer drill, 4 cutting edges SDS-plus Xtreme Plus	8.0	310	250	533590	
HD 4-C D10x 250/310 SDS-plus	Hammer drill, 4 cutting edges SDS-plus Xtreme Plus	10.0	310	250	533591	
HD 4-C D12x 260/310 SDS-plus	Hammer drill, 4 cutting edges SDS-plus Xtreme Plus	12.0	310	260	533592	
HD 4-C D14 260/310 SDS-plus	Hammer drill, 4 cutting edges SDS-plus Xtreme Plus	14.0	310	260	533593	
HD 4-C D16 260/310 SDS-plus	Hammer drill, 4 cutting edges SDS-plus Xtreme Plus	16.0	310	260	533594	
HD 4-C D8x 400/460 SDS-plus	Hammer drill, 4 cutting edges SDS-plus Xtreme Plus	8.0	460	400	533595	
HD 4-C D10x 390/450 SDS-plus	Hammer drill, 4 cutting edges SDS-plus Xtreme Plus	10.0	450	390	533596	
HD 4-C D12x 400/450 SDS-plus	Hammer drill, 4 cutting edges SDS-plus Xtreme Plus	12.0	450	400	533597	
HD 4-C D14x 400/450 SDS-plus	Hammer drill, 4 cutting edges SDS-plus Xtreme Plus	14.0	450	400	533598	
CH-PO 250 SDS-plus	Pointed chisel SDS-plus Xtreme	-	250		533599	
CH-FL 20x250 SDS-plus	Flat chisel SDS-plus Xtreme	20	250		533600	
CH-SC 40x250 SDS-plus	Spade chisel SDS-plus Xtreme	40	250		533601	
CH-TI 40x250 SDS-plus	Curved tile chisel, SDS-plus Xtreme	40	250		533602	
CH-PO 250 SDS-max	Pointed chisel SDS-Max Xtreme	-	400		533603	
CH-FL 25x400 SDS-max	Flat chisel SDS-Max Xtreme	25	400		533604	
CH-SC 50x400 SDS-plus	Spade chisel SDS-Max Xtreme	50	400		533605	
CH-TI 50x300 SDS-plus	Tile chisel SDS-Max Xtreme	50	300		533606	
CH SET SDS-max VE2	SDS-max chisel set: Pointed/flat chisel Xtreme	400	2-piece		533607	
CH SET SDS-max VE3	SDS-max chisel set: Pointed/flat/wide chisel Xtreme	400	3-piece		533608	
CH SET SDS-plus VE3	SDS-plus chisel set: Pointed/flat/wide chisel Xtreme	250	3-piece		533609	
	HD 2-C D5-10 Set SDS-plus	Hammer drill, 2 cutting edges SDS-plus Xtreme	5	110		414026
			6	110		
			6	160		
			8	160		
			10	160		
	HD 4-C D5-12 Set SDS-plus	Hammer drill, 4 cutting edges SDS-plus Xtreme Plus	5	110		533610
			6	110		
			8	110		
			6	160		
			8	160		
	CH/HD 4-C Set SDS-plus	Hammer drill, 4 cutting edges SDS-Plus Xtreme Plus Flat chisel SDS-Plus Xtreme Pointed chisel SDS-Plus Xtreme	5	110		533611
			6	110		
			6	160		
			8	160		
			10	160		
	CH/HD 2-C Set SDS-plus	Hammer drill, 2 cutting edges SDS-plus Xtreme Flat chisel SDS-plus Xtreme Pointed chisel SDS-plus Xtreme	5	110		533612
			6	110		
			6	160		
			8	160		
			10	160		
	HD 4- C Set 1 SDS-max VE4	Hammer drill, 4 cutting edges SDS-max Xtreme Plus	16	540		533717
			18	540		
			20	520		
			22	520		
	HD 4- C Set 2 SDS-max VE4	Hammer drill, 4 cutting edges SDS-max Xtreme Plus	18	540		533718
			20	520		
			22	520		
			32	570		
	HD 4- C Set 3 SDS-max VE5	Hammer drill, 4 cutting edges SDS-Max Xtreme Plus	16	540		533719
			18	540		
			20	520		
			22	520		
			25	520		

# Maximum dust protection on the construction site

## VAC 800-EC air cleaner for construction sites

Watch the video!



### Very efficient

Significantly reduces the pollutant load in rooms up to 100 sq. m within a short time.

### Very handy

No installation required. Set up, switch on – clean air. The filter is changed without the need for tools.

### Low incidental costs

When used properly, the HEPA 14 filter can be used for up to one year. The VAC 800-EC air cleaner is specially designed for continuous operation and impresses with its very low power consumption.

### Whisper mode

In special Night mode, the sound pressure level is only 38 dB (A). This means that the operating noise falls below the concentration disturbance threshold and is therefore also ideally suited to places such as classrooms.

### Light weight

Weighing just 7.2 kg, the VAC 800-EC is the quietest in its class, and this makes it easy to move.

### Robust construction

Specially designed for extreme conditions on construction sites. The VAC 800-EC is particularly robust, and boasts an impressive long service life.



### EC Whisper Turbine ("Made in Germany")

- Long run time
- Long service life
- Low service costs
- Low noise



**Tool-free "Top-Change" filter change**  
Thanks to simple operation of the quick-action clamping lever. Prevents unnecessary contact with spent filter cartridges.

## VAC 800-EC

### Order No. 532859

- 1x VAC 800-EC
- 1x HEPA filter H14
- 1x pre-filter mat G3
- 1x coarse filter G4
- 1x hose SH 125x5m C

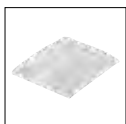





#### Work with negative pressure in the working area

A sluice should be installed to prevent dust from migrating into the environment outside the work area. The cleaned air is discharged from the working area via a hose or is fed back into the working area as cleaned air.

#### The mobile FLEX Air Cleaner can be put to use immediately and without the need to assemble anything

- Power consumption 170 watts
- Rated power consumption 1.7 - 1.45 A
- No-load speed 0-3930 /min
- Dust extraction connection Ø 125 mm
- Sound pressure level 1 m, 58 dB(A)
- Max. flow rate 544 m<sup>3</sup>/h
- Filter surface area H13 > 7.26 m<sup>2</sup>
- Fuse 10 VA
- Dimensions (L x W x H) 373 x 400 x 508 mm
- Cable length 3.5 m
- Weight 7.2 kg

#### Accessories

Product	Designation	Qty.	Order No.	
Hoses	SH 125 x 5 m C	1	477672	
	SH 125x6m C	1	488186	
	SH 205x7.5m C	1	500399	
Filter	Pre-filter mats G3	VFE VAC G3	10	477699
	Coarse filter G4	FE VAC G4	1	477702
	Activated carbon filter G4	FE VAC G4 AK	1	477710
	Fine dust filter F7	FE VAC F7	1	477729
	HEPA 13 filter	FE VAC H13/HEPA	1	477737
	HEPA 14 filter	FE VAC H14/HEPA	1	488194

# Precision right along the line

## Self-levelling crossline laser ALC 2/1-G/R



- Individually switchable horizontal and vertical laser line
- Anti-reflection lenses
- Range up to 50 metres/up to 70 metres with receiver
- Self-levelling can be switched off
- Simple operation
- Integrated Li-polymer rechargeable battery



### Order No. 530443

- 1x ALC 2/1-G/R
- 1x magnetic holder
- 1x carrying bag
- 1x USB cable
- 1x USB charger

**INCLUDING**  
tripod LKS 65-170 F 1/4



## Self-levelling crossline laser ALC 3/1-G/R

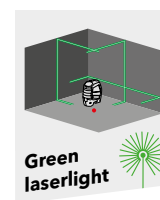

- With one horizontal and two vertical laser lines at a 90° angle plus plumb (red laser), individually switchable.
- Range up to 50 metres/up to 70 metres with receiver
- Anti-reflection lenses
- Battery operating period of over 6 hours



### Order No. 530444

- 1x ALC 3/1-G/R
- 1x magnetic holder
- 1x carrying bag
- 1x USB cable
- 1x USB charger

**INCLUDING**  
tripod LKS 65-170 F 1/4



## 360° cordless line laser ALC 3/360-G/R 10.8 kit



- Receiver mode
- One horizontal and two vertical 360° laser lines, individually switchable
- Plumb function
- Anti-reflection lenses
- Range up to 100 m, with receiver up to 120 m
- Self-levelling function can be switched off
- 3 brightness levels
- Dust-proof and splash-proof
- Optical warning signal when self-levelling range is exceeded

### Order No. 532862

- 1x ALC 3/360-G/R 10.8
- 1x laser target plate and glasses
- 1x laser universal holder
- 1x charger CA 10.8
- 1x rechargeable battery 2.5 Ah AP 10.8/2.5
- 1x carrying case L-BOXX® 136

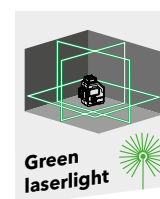

**INCLUDING**  
tripod LKS 65-170 F 1/4



**Safety information!** FLEX laser measuring devices comply with all international safety standards. They comply with laser class 2 or 2M according to DIN EN 60825-1: 2001-11 (wavelength 635-670 nm, output power < 1mW) and do not harm the eyes or skin when used as directed. Nevertheless, never look directly into the laser beam when using laser measuring devices.



## Laser rangefinder ADM 100 G up to max. 100 m

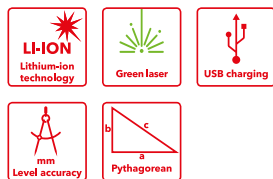

- Green laser for fast and precise measurements
- Length, surface, volume and indirect measurements
- Permanent angle measurement
- Up to 99 values can be stored with the memory function
- Continuous measurement mode
- Unit/sound button: Silent or with tone and setting of the required measuring unit
- Illuminated four-line display
- Housing protected against dust and splash water
- 1/4" connecting thread for tripods
- Operation possible with AAA 1.5 V batteries or a rechargeable battery



**ADM 100 G**  
Order No. 518964

- 1x lithium ion battery
- 3x AAA 1.5 V batteries
- 1x USB in micro-USB cable
- 1x protective bag

## Laser rangefinder ADM 70 G up to max. 70 m

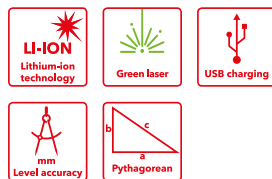

- Green laser for fast and precise measurements
- Length, surface, volume and indirect measurements
- Permanent angle measurement
- Up to 99 values can be stored with the memory function
- Continuous measurement mode
- Unit/sound button: Silent or with tone and setting of the required measuring unit
- Illuminated four-line display
- Housing protected against dust and splash water
- 1/4" connecting thread for tripods
- Operation possible with AAA 1.5 V batteries or a rechargeable battery



**ADM 70 G**  
Order No. 518956

- 1x lithium ion battery
- 3x AAA 1.5 V batteries
- 1x USB in micro-USB cable
- 1x protective bag

## Laser rangefinder ADM 30 Smart up to max. 30 m

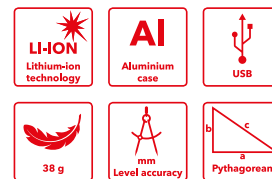

- Rapid determination of dimensions indoors
- Simple operation
- Length, surface area and volume calculation
- Indirect height measurement
- Continuous measurement mode
- Units can be switched between m/mm, inch/feet
- Integrated rechargeable battery
- Automatic switch-off
- Illuminated display
- Dust-proof housing



**ADM 30 Smart**  
Order No. 504599

- 1x ADM 30 Smart
- 1x hand strap
- 1x USB cable



## TWINPACK 18 V cordless vacuum lifter VLP 18 Grabo

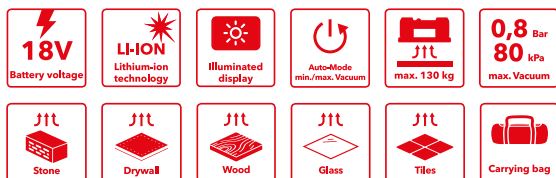

- The ergonomically-designed, portable electric vacuum lifter lifts and moves almost any object and puts it effortlessly into place. This vacuum lifter is ideal for various materials such as tiles, drywall panels, concrete blocks, glass, metals, furniture and large electrical appliances.
- Its powerful functionality ensures that heavy objects are handled both efficiently and reliably.
- Holding force of up to 170 kg depending on the material
- Permissible load-bearing capacity 130 kg
- Work safety has the highest priority. The vacuum lifter has an automatic suction function and the digital display continuously provides information about the current negative pressure
- With a powerful vacuum pump, stops automatically at maximum vacuum
- The electronic management system (EMS) protects the tool, extends its service life and increases efficiency

### TECHNICAL DATA VLP 18 GRABO

Rated air flow	20 l/min
Max. vacuum	0.8 bar
Max. load-bearing capacity	130 kg
Max. holding force	170 kg
Working temperature	0 °C ~ 60 °C
Dimensions L x W x H	300 x 184 x 121 mm
Battery voltage	18.0 V
Battery capacity	2.5 / 5.0 / 8.0 Ah
Weight without battery pack	1.48 kg



Up to 170 kg depending on the material

### Order No. 533346

- 2x VLP 18 Grabo
- 2x protective bag
- 1x charger CA 18.0
- 2x battery packs Li-Ion AP 18.0/2.5 Ah



## The alternative to the small cutting bench Diamond cutting wheel for stone CS 60 WET



- High-performance motor: extra-powerful, for cutting stone and milling joints
- Stepless cutting depth adjustment from 0-60 mm, with guide rail up to 54 mm. In a 0-44 mm mitre cut, with guide rail up to 38 mm
- Stepless angle adjustment for mitre cuts from 0-45°
- Cutting marking of 0°/30°/45° on the guide table for quick orientation
- High-quality disc guard and die-cast magnesium guide plate
- Rubber motor guard prevents splash water from being directly sucked in
- Water supply: for effective cooling of the diamond tool
- Quick-action brass coupling: for 1/2" water hose
- GFCI operator protection circuit breaker integrated into the cable



### Order No. 531029

- 1x diamond cutting wheel for stone CS 60 WET
- 1x key for tool changing
- 1x parallel stop
- 1x L-BOXX® 238
- 1x diamond cutting wheel with segmented cutting edge



INCLUDING  
GRS 160 guide rail



## Compact renovation sander for sanding up to edges LDE 16-8 125 R, Turbo-Jet II kit

- Electronics with speed stabilisation, soft start, overload protection and temperature monitoring
- Reliable 1600 watt high-power motor
- Steplessly adjustable no-load speed 4500-7800/min
- Anti-kickback, switches off the motor if the wheel gets jammed
- Disc guard with pivoting segment for sanding up to the wall
- Steplessly-adjustable, vibration-dampened ergonomic handle
- FLEX clip hose connection for Ø 32 mm snap coupling included in the basic package
- Recessed spindle lock to prevent accidental actuation
- Ideally suited to working on walls, ceilings and floors. Efficient and economical thanks due to optimum machine and sanding disc matching

### Order No. 513474

- 1x LDE 16-8 125 R
- 1x diamond backing pad Turbo-Jet II
- 1x dust extraction guard with brush ring
- 1x bail handle
- 3x cable holders
- 1x Allen key, WAF 4
- 1x face spanner
- 1x L-BOXX® 238 carrying case

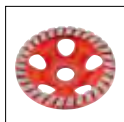

Also available as LD 16-8 125 R, Turbo-Jet II kit with constant speed, (Order No. 504939)

### INCLUDING

Screed-Jet diamond grinding disc Ø 125 mm (grinding disc for abrasive materials)



## Powerful 2400 watt renovation sander for surfaces, 180 mm LD 24-6 180, Turbo-Jet kit

- Elastic rubber suction ring with low-wear metal ring
- Dust extraction protects against abrasive dust
- Soft start for a safe start
- Restart protection after a power failure
- Dust extraction guard with continuous height adjustment
- Extraction nozzle 32 mm external Ø
- Very well suited to material removal from large areas
- Sanding plates of heights 22 mm to 28 mm are suitable.
- With steplessly adjustable, vibration-dampened ergonomic handle

### Order No. 513482

- 1x LD 24-6 180
- 1x Turbo-Jet diamond grinding disc, Ø 180 mm
- 1x dust extraction guard with rubber suction ring
- 1x suction adapter
- 1x clamping nut M 14
- 1x clamping flange WAF 17
- 1x Allen key, WAF 6
- 1x face spanner
- 1x bow handle
- 3x cable holders
- 1x carrying case



INCLUDING  
PCD grinding disc  
Ø180 mm

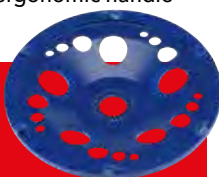

## RETECFLEX the universal tool for renovation, refurbishment and modernising RE 16-5 115, pointed scouring head kit

- Universal tool system that can be adapted for many refurbishment and modernisation applications. Compact, handy and perfectly suited to machining smaller areas and the edges of large areas
- Speed preselection, speed stabilisation by means of tachogenerator, soft start, restart interlock after power failure, overload protection and temperature monitoring
- Anti-kickback
- Special gearbox: special gear reduction provides high torque in the medium and lower speed range
- With steplessly adjustable, vibration-dampened ergonomic handle
- FLEX clip system. No adapter and reducing sleeves required
- Dust extraction guard: with stepless height adjustment
- Spindle lock

### Order No. 513504

- 1x RE 16-5 115
- 1x pointed scouring head
- 1 dust extraction guard for sanding Ø 115 mm brush ring
- 1x base for scouring Ø 80 mm
- 1x grinding disc Ø 115/M14 hook and loop, bowl
- 1 corundum Ø 115 sanding disc kit
- 1x bow handle
- 1x ring spanner, WAF 13
- 1x Allen key, WAF 4
- 3x fastening screws, M 8
- 1x L-BOXX® 238 carrying case

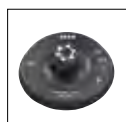

INCLUDING  
Diamond grinding disc  
Screed-Jet  
PCD grinding disc



You'll find the right industrial vacuum cleaner on Pages 30/31 or at [www.flex-tools.com](http://www.flex-tools.com)

## 2600 watt angle grinder L 26-6 230 TK-S



- Motor: heavy-duty and very efficient for strong grinding performance
- Soft start, restart protection after a power failure, overload protection, CDC constant speed control
- Anti-kickback
- SoftVib handle reduces vibrations, can be mounted in three positions
- Rear handle with soft insert can be rotated 90° to the clockwise and anti-clockwise for an optimum working posture
- Spindle lock

Order No. 466239

- 1x L 26-6 230 TK-S
- 1x carrying case
- 1x SDS-Clic quick-release nut M 14
- 1x diamond cutting wheel, standard concrete Ø 230 mm



Ø 230



## Dust extraction guard and diamond cutting system DCG L 26-6 230 G kit

- Ready to use right away, angle grinder with ready-fitted extraction hood in a case. Universal diamond cutting wheel 230 mm including
- Powerful angle grinder L 26-6 230 with soft start, restart protection, overload protection, CDC constant electronics, anti-kickback function
- Fully enclosed extraction hood for efficient dust extraction
- Direct connection via Flex Clip system
- Base plate with rollers for easy feed. Can be used with or without guide rail
- Depth stop with scale for presetting the cutting depth and any desired start of cut (plunge cut) with and without guide rail (max. 55 mm with or 60 mm without rail).
- Side handle, can be fitted on either the right or left



Ø 230

Order No. 494674

- 1x L 26-6 230 angle grinder
- 1x dust extraction guard DCG AG 230
- 1x diamond cutting wheel, universal Ø 230 mm
- 3x DCG AG kit rubber strip
- 1x DCG AG 230 spacer ring L26/24/22
- 1x SoftVib handle
- 1x clamping flange
- 1x clamping nut M 14
- 1x Allen key, WAF 6
- 1x face spanner BL 5
- 1x guide rail GRS 80
- 1x carrying case with inlay



## Dust extraction guard DCG AG 230

Detachable dust extraction guard with efficient dust extraction for precise cuts when working with diamond cutting wheels in conjunction with 230 mm angle grinders. Extremely stable, the stabiliser element prevents distortion caused by the side weight of the angle grinder. Base plate with rollers for easy feed, the side handle can be fitted on either the left or right. Incl. suction connection for FLEX clip system and adapter for guide rail. Depth stop with scale for presetting the cutting depth for use with or without a guide rail. Maximum cutting depth 60 mm.

Order No. 471895

- 1x dust extraction guard DCG AG 230





## 1500 Watt angle grinder LE 15-11 125



- With soft-start, restart interlock, temperature monitoring and CDC constant electronics
- Comprehensive dust protection for motor and gearbox
- Anti-kickback, switches off the motor if the wheel gets jammed
- Compact and ergonomic design
- Disc guard adjustable without tools
- SoftVib handle with integrated, patented clamping nut wrench and vibration damping



Ø 125

### Order No. 501638

- 1x LE 15-11 125
- 1x disc guard 125 Ø grinding
- 1x disc guard with removable edge segment SG-R D125
- 1x disc guard kit DE AG D125 kit
- 1x suction adapter SAD-C D25-32 AS
- 1x suction adapter SAD-C 32 AS
- 1x SoftVib handle
- 1x clamping flange
- 1x clamping nut M 14
- 1x L-BOXX® 136 carrying case



### INCLUDING disc guard kit DE AG D125 kit

Dust extraction guard kit for working with cutting discs for 125 mm angle grinders. Consisting of extractor and aluminium cover. Can be fitted to existing disc guard without using tools.



### INCLUDING disc guard with removable edge segment SG-R D125

Enables the operator to work very close to edges at maximum extraction power. Hexagonal recess bolt for height adjustment allows quick adjustment of dust extraction guard to tool height. Note: An angle grinder with at least 1500 watts is recommended for working with the dust extraction guard and diamond grinding disc. Suitable only for angle grinders with a latching mechanism disc guard.



## Thin cutting disc (1 mm) for stainless steel/steel

**Xtreme PLUS**

Straight, for fast cutting of thin-walled pipes, profiles and sheet metal without applying force. Reduced cutting pressure and minimal chipping ensure a cool cut, low-burr to burr-free edges, no blue discolouration and reduced flying sparks. Packaging in a can with freshness seal ensures a 30% longer shelf life.

### Order No. 533348

- 10 in a tin

Available from  
October 2024



## 800 watt angle grinder L 811 125

Ø 125



- Comprehensive dust protection for motor and gearbox
- Restart protection after a power failure
- Longer service life thanks to optimised cooling and modified carbon brush geometry
- Light, ergonomic design, short and very handy
- Disc guard adjustable without tools



Order No. 494682

- 1x L 811
- 1x disc guard 125 Ø grinding
- 1x handle
- 1x clamping flange
- 1x clamping nut M 14
- 1x face spanner

## 1100 watt angle grinder L 1100 125

Ø 125



- Compact and ergonomic design
- Extremely light and handy
- Ergonomic arm working posture thanks to side handle mounted at an angle
- Restart protection after a power failure
- Soft start
- Spindle lock
- Lockable slide switch
- Disc guard adjustable without tools
- Additional handle

**NEW**

Available from  
October 2024



Order No. 532609

- 1x L 1100 125
- 1x handle
- 1x disc guard 125 Ø grinding
- 1x clamping nut M 14
- 1x face spanner
- 1x clamping flange

## 1400 watt angle grinder L 1400 125

Ø 125



- Soft start, restart protection after a power failure, temperature monitoring, CDC constant speed control
- Motor: heavy duty with a high level of efficiency
- Longer service life thanks to optimised cooling and carbon brush geometry
- Comprehensive dust protection for motor and gearbox
- Ergonomic arm working posture thanks to side handle mounted at an angle
- Tool-free adjustable guard hood with clamping lever
- Lockable slide switch
- Spindle lock



Order No. 492329

- 1x L 1400 125
- 1x disc guard 125 Ø grinding
- 1x handle
- 1x clamping flange
- 1x clamping nut M 14
- 1x face spanner

## 2200 watt angle grinder L 2200 230

Ø 230



- Durable motor and gearbox housing. The stable and robust steel gearbox and the spindle bearing protected by a metal cap increase reliability and service life.
- Rear shaft handle with soft padding for secure grip
- Switch with lock-off switch and interlock
- Restart protection after a power failure
- Soft start for a comfortable and smooth start
- Spindle lock
- Tool-free adjustable guard hood with clamping lever
- Cutting guard (389625) or cutting guard cover (446068) as an optional accessory



Order No. 492280

- 1x L 2200 230
- 1x disc guard 230 Ø grinding
- 1x handle
- 1x clamping flange
- 1x clamping nut M 14
- 1x face spanner

## 900 watt angle grinder LE 9-11 125

Ø 125



- With speed stabilisation, speed control, soft start, restart interlock after power failure, overload protection
- Variable speed adjustment (6 settings)
- Motor: heavy duty with a high level of efficiency
- Compact, streamlined and ergonomic design
- Anti-kickback, switches off the motor if the wheel gets jammed
- Disc guard adjustable without tools



### Order No. 512818

- 1x LE 9-11 125
- 1x disc guard 125 Ø grinding
- 1x handle
- 1x clamping flange
- 1x clamping nut M 14
- 1x face spanner

**INCLUDING**  
FixTec quick-clamp  
nut M 14



## 1700 Watt angle grinder LBE 17-11 125

Ø 125

Variable speed



- Also with variable speed 2800-11,500/min
- Heavy-duty, highly-efficient motor
- Longer service life thanks to optimised cooling and modified carbon brush geometry
- Comprehensive dust protection for motor and gearbox
- With mechanical brake, stops the tool in 3.5 seconds
- Disc guard adjustable without tools
- Lockable slide switch
- SoftVib handle with integrated clamping nut wrench and vibration damping



### Order No. 502022

- 1x LBE 17-11 125
- 1x disc guard 125 Ø grinding
- 1x SoftVib handle
- 1x clamping flange
- 1x clamping nut M 14

**INCLUDING**  
1200 watt  
angle grinder  
L 12-11 125



## 2200 / 800 watt angle grinder L 2200 230 / L 811 125

Ø 230

Ø 125

### 2200 watt angle grinder L 2200 230

- Max. grinding tool Ø 230 mm
- No-load speed 6500 /min
- Power consumption 2200 watts
- Tool holder M 14
- Clamping collar Ø 64 mm
- Cable length 4.0 m
- Weight 5.8 kg

### 800 watt angle grinder L 811 125

- Max. grinding tool Ø 125 mm
- No-load speed 12,000 /min
- Power consumption 800 watts
- Tool holder M 14
- Clamping collar Ø 40.3 mm
- Cable length 4.0 m
- Weight 2.0 kg



### Order No. 492302

- 1x L 2200 230
- 1x L 811 125
- 1x carrying case

## 2200 / 1010 watt angle grinder L 2200 230 / L 1001 125

Ø 230

Ø 125

### 2200 watt angle grinder L 2200 230

- Max. grinding tool Ø 230 mm
- No-load speed 6500 /min
- Power consumption 2200 watts
- Tool holder M 14
- Clamping collar Ø 64 mm
- Cable length 4.0 m
- Weight 5.8 kg

### 1010 watt angle grinder L 1001 125

- Max. grinding tool Ø 125 mm
- No-load speed 12,000 /min
- Power consumption 1010 watts
- Tool holder M 14
- Clamping collar Ø 40.3 mm
- Cable length 4.0 m
- Weight 2.2 kg



### Order No. 492310

- 1x L 2200 230
- 1x L 1001 125
- 1x carrying case



# Metal work

The 18 V cordless TRINOXFLEX sets make working on metal surfaces easy anywhere.

## 18 V cordless belt file FBE 30 18-EC

- Brushless motor, greater efficiency, longer service life
- Unique tool attachment with quick-release coupling for changing the four system attachments without using tools
- Head can be swivelled through 140°. Sanding arms can be used with 9 mm or 30 mm
- Sanding arm adjustable for belt lengths of 520 mm and 533 mm
- Sanding arm working length up to approx. 12 cm
- Change sanding belt: quickly and without tools

### Order No. 532117

- 1x FBE 30 18-EC
- 1x sanding attachment, belt file BF 140
- 2x sanding belts ZIRCOFLEX P60
- 2x sanding belts ZIRCOFLEX P120



## 18 V cordless pipe belt sander BRE 50 18-EC

- Brushless motor, greater efficiency, longer service life
- Unique tool attachment with quick-release coupling for changing the four system attachments without using tools
- High-quality sanding arm with spring suspension: made of light alloy with 2 deflection rollers. For optimum wrap-around of pipes up to max. 270°
- Change sanding belt: quickly and without tools

### Order No. 532118

- 1x BRE 50 18-EC
- 1x sanding attachment, pipe belt BR 50
- 2x sanding belts ZIRCOFLEX P60
- 2x sanding belts ZIRCOFLEX P120



## 18 V cordless fillet weld sander LKE 152 18-EC

- Brushless motor, greater efficiency, longer service life
- Unique tool attachment with quick-release coupling for changing the four system attachments without using tools
- For precision work on surfaces, sanding work in particularly tight angles, corners and hard-to-reach places
- Microprocessor control: Speed preselection, speed stabilisation by means of tachogenerator, soft start, restart interlock after power failure, overload protection and temperature monitoring

### Order No. 532120

- 1x LKE 152 18-EC
- 1x sanding attachment for fillet weld BS 152



## 18 V cordless burnisher BSE 50 18-EC

- Brushless motor, greater efficiency, longer service life
- Unique tool attachment with quick-release coupling for changing the four system attachments without using tools
- Adjustable burnishing attachment, allows working close up to the edge, also suitable for narrow rollers, incl. parallel stop. Tool-free grinding tool change via patented quick-change system
- For optimum finishing of various materials, for burnishing, texturing, polishing, brushing, smoothing, de-rusting and deburring steel and stainless steel surfaces

### Order No. 532119

- 1x BSE 50 18-EC
- 1x sanding attachment for burnishing BS 50



You'll find the right batteries and chargers on Pages 10/11.



Further information about metalworking with the TRINOXFLEX system can be found on our website!



### 18 V variable-speed cordless straight grinder DGE 25 18.0-EC



- Very slender and light machine for optimum handling. Only 147mm grip circumference
- Speed preselection in 4 steps (10,000 / 15,000 / 20,000 / 25,000 rpm)



**INCLUDING**  
P kit 55 R

Also available in an L-BOXX®  
(without battery and charger)  
(Order No. 518972).

#### Order No. 532115

- 1x DGE 25 18.0-EC
- 1x collet 6 mm Ø
- 1x open-end spanner a/f 17



### Variable-speed straight grinder DGE 8-32



- Powerful and robust 800 W motor
- Variable speed 10600 - 32000 rpm
- Slender and light machine for optimum handling.
- 43 mm clamping neck for stationary fixing or handle attachment
- Handle protective cover for safe machine guiding
- Lockable, On/Off switch at the side

#### Order No. 522279

- 1x DGE 8-32
- 1x collet 6 mm Ø
- 1x open-end spanner a/f 17





## 1400 watt metal-cutting circular saw CSM 4060



- Exact sawing of metal without cooling fluid
- Chip collection container with viewing window:
  - Large dimensions
  - Can be emptied without using tools
- Guide plate adjustable without using tools, infinitely variable sawing depth adjustment up to 63 mm
- Special carbide-tipped saw blades: nearly burr-free cuts, trimming threaded bars possible without recutting the thread.
- Switch with lock-off switch and interlock
- Maximum cutting depths:
  - Solid material / flat steel: 6 mm
  - Round material: 20 mm
  - Hollow sections: 63 mm

### Order No. 506044

- 1x CSM 4060
- 2x carbide saw blades for steel
- 1x parallel stop
- 1x combination wrench
- 1x protective goggles
- 1x carrying case



**INCLUDING**  
800 watt angle  
grinder  
L 811 125



## 850 watt metal-cutting band saw with swivelling saw frame SBG 4910



- Can be used with sawing bench or guided manually
- Stepless and tool-free adjustment of the cutting angle from 0° to 45°
- 3-point ball-bearing saw blade guide for optimum blade control

### Order No. 406236

- 1x SBG 4910
- 1x parallel stop
- 1x bimetal saw blades
- 1x chuck jaws SBG-SP 10 VE2





### Cordless band saw SBE 64 18-EC

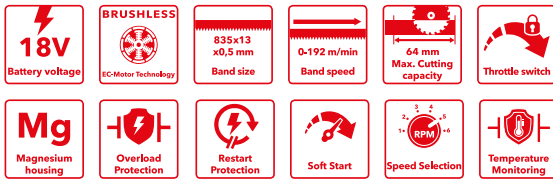

- A perfectly balanced band saw thanks to its design, supported by optimum weight distribution of the battery and motor.
- The SBE is particularly suitable for spark-free cutting of metal in environments where there is a risk of fire
- Brushless motor with greater efficiency and a longer service life
- Adjustable blade speed for perfect cuts in a variety of materials
- Toolless saw blade changing
- Integrated LED lamp for optimum illumination of the work area.
- Ergonomically designed, non-slip rubber-coated handle
- With metal bracket, non-slip for flexible attachment
- The electronic management system (EMS) protects the tool, extends its service life and increases efficiency

Order No. 531748

- 1x SBE 64 18-EC
- 1x bimetallic saw blade
- Carrying case TK-L 238



Adjustable blade speed for perfect cuts in a variety of materials.



Tool-free saw blade change, with an additional saw blade cover providing increased safety during use.



### Cordless band saw SBE 127 18-EC

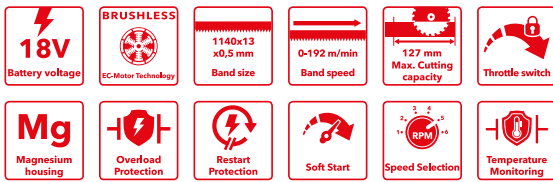

- See SBE 64 18-EC for technical configuration



Order No. 531749

- 1x SBE 127 18-EC
- 1x bimetallic saw blade
- 1x carrying case



### Work table WB SBE 127 for cordless band saw SBE 127 18-EC

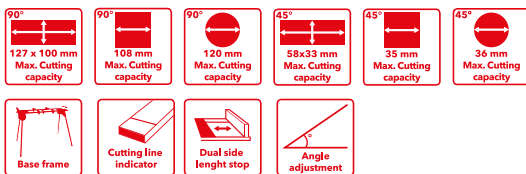

- For using the SBE 127 18-EC as a semi-stationary band saw
- Simple installation with a large rotary knob and clamping lever for quick fastening
- The arm is spring-supported and supports the weight of the band saw
- Easily legible 0° - 45° scale
- Includes sturdy vice with insert jaws for pipes and other profiles with sensitive surfaces
- With flexible length stop on both sides, up to 310 mm on the right and 380 mm on the left
- If required, the table can be mounted on the WB 110-260 base frame.

Order No. 531750

- 1x WB SBE 127





# Workshop to go

**Everything ready to go, everything to hand: The FLEX STACKPACK™ is the mobile workshop in trolley form, offering you many individual configuration options. The toolbox of today.**



# FLEX STACK PACK™



Removable handle

Quick release

Metal latch

Aluminium-reinforced corners  
with fastening interface

Front handle

Cable wrap TKH KW (accessory)

All boxes in Protection  
Class IP65

Tool holder rails Side  
TKH WS (accessory)

Robust wheels Ø 23 cm

Spirit level holder TKH  
ADL (accessory)

The STACKPACK™ is a real organisational talent on the construction site! Specially developed for craftsmen, it impresses with features such as a removable handle, a practical quick-release fastener and a sturdy metal latch. The aluminium-reinforced corners with fastening interface ensure that the tools are always neatly and securely stowed away. The front carrying handle makes it easy to carry, while the integrated cable winder is perfect for organising your power tools.

The STACKPACK™ is rainproof and waterproof with protection class IP 65, so your equipment is protected from dust and splash water even in extreme working environments. What's more, the STACKPACK™ is absolutely all-terrain thanks to its robust 23 cm wheels - effortless movement even on uneven terrain is no challenge for the STACKPACK™. Choose the STACKPACK™ and bring order and efficiency to your construction site!



# The all-round package for all jobs

## TK-L SP KIT-1

### STACKPACK™ Advantage set 1 consisting of

- Roller Box TK-L SP RB
- Medium Box TK-L SP BO
- Big Organizer TK-L SP BO

Order No. 531461



Now at a value price!

### Small Organizer TK-L SP SO

- 11 kg loading capacity Order No. 531468
- Clear, transparent cover
- Incl. four accessory containers with partitions



### Big Organizer TK-L SP BO

- 22 kg loading capacity Order No. 531467
- Incl. eight accessory containers with partitions



### Top Box TK-L SP TB

- 50 kg loading capacity Order No. 531466
- Incl. four accessory containers with partitions



### Roller Box TK-L SP RB

- Robust tyres Ø 23 cm Order No. 531464
- 110 kg loading capacity
- Universal hook
- Removable handle
- Incl. removable accessory container
- Gas pressure springs



### Medium Box TK-L SP MB

- 63 kg loading capacity Order No. 531465
- Incl. removable accessory container
- Metal-reinforced folding handle
- Gas pressure springs



### Cable wrap TKH KW

Order No. 531472



### Spirit level holder TKH ADL

Order No. 531469



### 41-piece bit kit DB 41

- Variable content set-up Order No. 530494
- FLEX STACK PACK™ stackable inside and on top of each other
- Easy opening with a button
- Fixed locking of the stacking function

Empty box also available (Order No. 530535).



### 25-piece bit kits

- **DB Bulk PH2** Order No. see left  
Order No. 530489  
Promotion No. 127
- **DB Bulk T20**  
Order No. 530490  
Promotion No. 128
- **DB Bulk T25**  
Order No. 530491  
Promotion No. 129
- **DB Bulk T30**  
Order No. 530492  
Promotion No. 130
- **DB Bulk T40**  
Order No. 530493  
Promotion No. 131



### Tool holder rails Side TKH WS

Order No. 531471



### 31-piece bit kit DB 31

Order No. 533103



NEW

# The organiser package in the advantage set

## TK-L SP KIT-2

### STACKPACK™ Advantage set 2 consisting of

- Trolley TK-L SP RD
- Drawer Box TK-L SP 3DB
- Drawer Box TK-L SP 2DB
- Worktop TK-L SP WT

Order No. 533247

**NEW**



**Now at a value price!**

All items shown on page 53 are available from October 2024!

### Box TK-L SP C

- Quick-release fasteners
- Ready for accessories
- 32 kg loading capacity
- Bumper

Order No. 533238



**NEW**

### Drawer Box TK-L SP 3DB

- 3 self-locking drawers incl. dividers
- Robust steel rails
- 32 kg loading capacity

Order No. 533239



**NEW**

### Drawer Box TK-L SP 2DB

- 2 self-locking drawers incl. dividers
- Robust steel rails
- Oversized bottom drawer
- 32 kg loading capacity

Order No. 533240



**NEW**

### Garage Box TK-L SP CB

- Self-locking door
- Large storage space
- Quick-release fasteners
- 32 kg loading capacity

Order No. 533241



**NEW**

### Deep Box TK-L SP DO

- Quick-release fasteners
- Deep compartments with removable dividers
- 27 kg loading capacity

Order No. 533242



**NEW**

### Tool bag TK-L SP TT

- Simple swivel-action handle
- 1x padded shoulder strap
- High-quality polyester material
- 44 pockets and compartments

Order No. 533243



**NEW**

### Small bag TK-L SP TT

- Hook & Metal clip
- High-quality polyester material
- Double wall with 6 pockets

Order No. 533244



**NEW**

### Worktop TK-L SP WT

- 3/4" plywood panel, renewable
- Integrated storage pockets
- Tool holders
- Folding hook

Order No. 533245



**NEW**

### Trolley TK-L SP RB

- Effortlessly move loaded STACK PACK™ boxes
- Robust wheels can be turned through 360° for maximum mobility
- Loading capacity up to 110 kg

Order No. 533246



**NEW**

**18V**

**Li-Ion**  
Power System

THERMA-TECH™  
**X LITHIUM**  
POWER



**Get even more FLEX power  
now with your  
FREE BATTERY!**





# Bright prospects

Do you love perfect paint surfaces? If so then FLEX Automotive Systems is exactly what you need. Here you'll find everything to do with polishing technology.



